

## CLAY TOBACCO PIPES AND PIPEMAKERS FROM THE ISLE OF WIGHT

By DAVID A HIGGINS

### ABSTRACT

*The Isle of Wight is one of the few places in Britain where pipe clay can be found and this resource was exploited as a raw material and for making pipes from the early seventeenth century onwards. Both the clay and manufactured pipes appear in shipping records of goods exported but, despite this, little research into pipemaking on the island has been carried out. Recent English Heritage excavations at Carisbrooke Castle provided the catalyst for this study, which has examined four key groups from the Isle of Wight to provide an overview of the pipes produced and the pipemakers who made them. The bowl forms and makers' marks are described, illustrated and discussed, while an appendix provides detailed biographies for all the pipemakers known to have worked on the island. This study brings together the current state of knowledge regarding pipes and pipemaking on the Isle of Wight and provides a reference point for future work on the subject.*

### INTRODUCTION

The Isle of Wight is one of the few places in the British Isles that produced and exported pipe clay, as well as having a good number of documented pipemakers who worked on the island itself. Despite this, there has been very little work on the local pipes themselves and certainly no extensive studies of the pipes and pipemakers such as have been prepared for Poole (Markell 1992), Christchurch (Markell 1983), Southampton (Atkinson 1975; Higgins 2011) and the Portsmouth Harbour region (Fox & Hall 1979; Fox & Barton 1986). Relatively few pipes appear to have been collected from excavations and the only substantive publication is a report on pipes from the twentieth

century excavations at Carisbrooke Castle (Brereton 2000).

The more recent excavations carried out by English Heritage at Carisbrooke Castle in 2006 and 2008–9 (Russell 2017, this volume) produced a total of 716 fragments of clay tobacco pipe comprising 76 bowl, 623 stem and 17 mouthpiece fragments. This is a significant assemblage and one that ranges in date from the early seventeenth century through to the early twentieth century. Although most of the pipes were recovered from disturbed deposits that do not directly relate to excavated features on the site, they still constitute one of the largest excavated groups to have been recovered from the Isle of Wight as a whole. The recent Carisbrooke Castle finds also include a good number and range of the marked and decorated pieces that were produced locally. These make a useful contribution to the meagre evidence available from the rest of the island, especially when combined with more complete examples of the same types recovered from elsewhere.

The new finds from Carisbrooke have provided an opportunity to review the existing state of knowledge regarding the pipemaking industry on the island and to add to the known corpus of bowl forms, marks and decorative motifs that were being used there. For this study, the excavated finds have been compared with previously published material from the castle (Brereton 2000) as well as three other significant collections from the island. The first is an unpublished group of bowls recovered from excavations at The Sun Inn, Holyrood Street, Newport and now in the Isle of Wight museum service store (PRN 1339). This site produced a good collection bowls, mostly dating from around 1660–1720, which provide complete examples of local forms that complement the

more fragmentary examples from the castle. The second group is the previously unpublished type series of bowl forms recovered from the 1978 excavations on the site of the Lord Louis Library in Orchard Street, Newport (Museum Service; PRN 1543). This was the site of the principal pipe factory on the island from at least the early nineteenth century onwards and the products of three successive makers are represented (and a fourth is known from pipes found elsewhere). Most of the pipes produced during this period were marked and decorated and once again, many of these finds provide more complete examples of fragmentary specimens recovered from the castle excavations. Finally, the author has in his possession a reference collection that was built up over a number of years by a private individual on the island. The pipes in this collection date from the seventeenth century onwards and include a wide range of local types. Although now individually unprovenanced, the collection was assembled from a number of local sources including kiln waste from the Orchard Street factory in Newport, finds from the Medina River near Cowes (particularly the earlier pipes, and almost certainly a pipe marked IOHN STEPHENS with an intact bowl) and late material from a bottle dump at Newport. The local marked and decorated forms in this collection often provide better examples of fragmentary specimens from the castle excavations.

Having compared the newly excavated pipes with this study material it was evident that the finds from the island included a wide range of bowl forms and styles, with a significant number of marked and decorated pieces amongst them. These proved hard to identify or parallel for two reasons. First, the only published list of pipemakers for the island is mixed amongst the Hampshire entries published by Oswald in 1975, and these entries are very brief and now rather out of date. Second, there are very few published examples of bowl forms, marks or decorated pipes from the island to use for reference. In order to address these problems, a new list of pipemakers has been prepared (Appendix 1), and a corpus of bowl forms compiled to illustrate the evolution of pipe styles, marks and decoration on the island (Figs 1–12).

The following sections provide an overview of pipemaking on the island and set the new finds from the castle excavations within their wider context.

## GEOLOGICAL BACKGROUND

The Isle of Wight is one of the few places in the country where good quality pipe clay can be found. This clay is terrestrial in origin, dating from the early tertiary period when it formed as outwash from weathering of granites in the south-west peninsular. The deposits found on the Isle of Wight are part of the same formation as those found in the Poole Harbour basin. They occur as a thin band in what is now known as the Bracklesham Group of the Poole formation (formerly the Bagshot Beds). This clay outcrops next to the sands at Alum Bay at the west of the island, where it occurs as near vertical beds. These could have been worked from the beach or followed inland and extracted by mining. It certainly seems to be a mine that is depicted in a 1798 engraving of a pipe clay pit at Bonchurch by I. Hassell (British Library: K Top Vol 15, 19.d), since it appears that the clay is being hauled out of a shaft on a rope.

The geological memoir also notes quarrying at a site about half a mile ESE of East Aston (near Freshwater). Most pipeclays are thought to occur in the west and south-west corner of the island, although the 1798 engraving shows extraction at Bonchurch and Venables (1860, 66) says that “there is a *pipe factory*, supplied from a vein of pipe-clay at Down End, above Arreton” (the pipe factory mentioned was probably that in Newport, not at Down End itself). Later in the same book Venables notes (p351) that, “the beds of Pipe-clay are not much used, it being found difficult to work them cleanly, owing to the narrowness of the veins and the tendency of the surrounding cliffs to founder.” This appears to be a more general statement about pipe-clay from the island, especially since he has earlier (p305) referred to the thin vein of pipe-clay at Alum Bay.

Although the deposits of pipeclay were not as extensive or deep as those found in south Devon and Dorset, they would still have provided an

important resource. As early as 1619 there were leases controlling the extraction of pipeclay in the Poole area (Cooksey 1980, 337) and the clay was in demand for a number of other industrial uses, quite apart from making pipes. In 1662 Fuller, writing of tobacco pipe clay in Dorset (p277), says that, "This is a fine clay, which will burn white (while others turn red) found in several parts of England; but so far from the sea, it will not quit cost of portage to London, save from two places, 1. Poole, in this county. This wrought alone makes an hard pipe, but so shrunk and shrivelled, it is unhandsome to the eye. 2. Isle of Wight. This wrought alone, makes a fair and full pipe, but so brittle, that it is uncervicable [*sic*] for use. Both compounded together make these utensils both hard and handsome. This clay brought to London by ship for ballast, is there worth about thirty shillings the tun [*sic*]." This makes it clear that not only was pipeclay from the Isle of Wight being exploited by the seventeenth century, but also that its qualities for pipe making were already well understood.

Walker notes shipments of pipeclay and pipes from the Isle of Wight to Brighton in 1666, showing that both the raw material and the manufactured goods were being exported to the mainland during the seventeenth century (Walker 1977, 221). Walker goes on to record shipments of clay from the Isle of Wight to various destinations all along the south and east coasts of England (ranging from Plymouth to Newcastle-upon-Tyne) during the late seventeenth and early eighteenth centuries. The local availability of pipeclay coupled with the island's maritime trading connections would have encouraged pipemaking and so it is not surprising that there appears to have been a strong tradition of pipemaking on the island from the seventeenth century onwards. As recently as the early 1900s there was still a good trade in pipes from the Isle of Wight to France (see biography of James Edgar in Appendix 1).

## THE PIPEMAKERS

In the absence of an up to date list of pipemakers for the island, a new list has been compiled using the readily available information from

previous publications and easily accessible Internet sources (Appendix 1). It has not been possible to look at original archives as part of this study and so there will doubtless be a lot more information that can be added, particularly for the seventeenth and eighteenth centuries. Despite this, the new list does at least provide a framework against which the pipe finds can be compared and identified.

The earliest recorded maker is Thomas Strange, who married at Newport in 1654, where he was presumably working. This shows that pipe making was already taking place on the island by the middle of the seventeenth century (and was on a large enough scale for pipes to be exported by 1666; see above). There was also pipemaking in West Cowes by 1683, when Stephen Summers was removed from there to Newport.

During the first half of the eighteenth century the Stephens family of Newport appear to have been the island's principal pipemakers, with at least five members of the family being recorded in this trade (Edward, Elizabeth, John (I), John (II) and Richard). John Stephens (II) held property in Crocker Street and was involved in malting and brewing as well. A midden deposit containing 12 of his marked pipes, possibly deriving from his kiln waste, has been found nearby (Trott 2001). Pipes made by John Stephens have not only been found on the mainland at sites such as Gosport (Oswald 1991), Portsmouth (Fox & Barton 1986, fig. 127.128) and Southampton (Atkinson 1975, fig. 13) but were also exported overseas, since examples have been found at Castle Cornet, Guernsey (David 2003, 239) and at Louisbourg in Nova Scotia (Walker 1967, fig. 3). Richard Stephens also exported his wares from the island, with examples being recorded from Hythe (Hants), Portsmouth, Fareham and Guernsey (David 2003, 239).

The other notable early eighteenth-century maker is John Ally, whose stamped stem mark includes a distinctive pair of crossed pipes (Fig. 5, 42). Four examples of this mark were found in a midden deposit in Newport, together with three armorial bowls depicting the Hanoverian Arms and with the moulded initials IA on their spurs (Trott 2001). Trott attributes these three pipes to a Bristol maker, but this seems a very

unlikely source and they are almost certainly local pipes produced by John Ally. There is also a pipe of c1690–1730 with the moulded mark WA from the castle (Fig. 3, 23), perhaps for William Ally, and other examples of this mark has previously been found there (Brereton 2000, 170), as well as full name stamps from Portsmouth (Fox & Barton 1986, fig. 121.98), which are attributed to a Newport maker of this name. Pipes with moulded WA heel initials and full name stem stamps for this maker have also been recorded from Castle Cornet, Guernsey (David 2003, 240). A William Ally (occupation unknown) baptised a son John at Newchurch in 1692, who could be the later Newport pipemaker of that name. A pipemaker called William Ally is also recorded in Winchester from c1730–77 (Oswald 1975, 171) and there is also a reference to a later William Alley working in Newport in 1773. Further work is clearly needed, but it is possible that the Ally/Alley family of pipemakers worked in Newport for at least three generations, with another branch having moved to Winchester.

The reference to William Alley in 1773 is the only record of a pipemaker during the second half of the eighteenth century, but this is probably due, at least in part, to a lack of documentary research for this period. John Jones, for example, is recorded as a Newport pipemaker in the 1830s and 1840s and marked pipes are known, showing that he ran his own business. He was, however, an old man at this time (born c1760) and so he is likely to have been pipe-making from c1780 onwards. Jones worked in Orchard Street, almost certainly at number 18, which appears to have been the principal manufactory on the island during the nineteenth century. Jones appears to have passed the running of the business over to Robert Cole, to whom he may have been related, by 1839. Cole then ran the business until c1885, when it was taken over by James Dyer, who ran it until his death in 1899. Finally, the factory was taken over in the early 1900s by Leonard Andrews, who operated it until at least 1911. Nineteenth-century pipemaking also appears to have taken place at Whippingham, near Cowes (where a memory of the trade may well be preserved in the name ‘Tobacco Pipe Copse’) and possibly also in Ryde. The last pipemaker on the island

was Edward James Edgar, who worked at Newport until he retired in about 1938.

Table 1 below shows the numbers of pipemakers for the island recorded during each decade. As noted above, the seventeenth and eighteenth-century records have not been systematically searched and pipemakers for this period are almost certainly underrepresented. Likewise, the sudden peak in the mid-nineteenth century is largely due to the much more detailed documentation available from census returns after 1841, which list employees as well as master pipemakers. These caveats aside, the table does show that pipemaking became established during the seventeenth century with a notable peak of activity during the first half of the eighteenth century. There was a decline in the trade during the second half of the eighteenth century followed by a marked resurgence by the mid-nineteenth century. The trade then slowly dwindled in the face of competition from other types of pipe (particularly briar and meerschäum) and as a result of a change to cigarette smoking, especially from the 1880s onwards when mechanised production reduced their cost significantly. Some production continued until the 1930s but it had probably finished by the Second World War. This pattern is strikingly similar to that observed in Portsmouth, Fareham and Southampton (Fox & Hall 1979, fig. 22; Arnold 1977, fig. 6) and shows that the fortunes of the island’s pipemakers should not be viewed in isolation, but were part of a wider regional trend.

## THE PIPES

In this section the recent finds from the castle excavations are compared and contrasted with other material from the island so as to provide a broader narrative for the pipes that were being produced/used over time. Some of the 2006–8 stem fragments excavated at Carisbrooke are likely to date from the first half of the seventeenth century but no recognisable bowl forms dating from before the middle of the century were recovered. The absence of early forms may be due to their having become too fragmented to recover since earlier forms were certainly in use at the castle, as can be

*Table 1* The total number of documented pipemakers on the Isle of Wight during each decade

<i>Decade</i>	<i>No. of pipemakers</i>	<i>Decade</i>	<i>No. of pipemakers</i>
1610s	0	1780s	0
1620s	0	1790s	0
1630s	0	1800s	0
1640s	0	1810s	0
1650s	1	1820s	1
1660s	0	1830s	1
1670s	0	1840s	9
1680s	1	1850s	12
1690s	0	1860s	6
1700s	4	1870s	5
1710s	5	1880s	6
1720s	1	1890s	4
1730s	2	1900s	3
1740s	2	1910s	2
1750s	3	1920s	1
1760s	0	1930s	1
1770s	1		

seen from previous finds (Brereton 2000, fig. 63.1–4). During the early part of the century heel types seem to have been the dominant form in use. Around the middle of the century roughly equal numbers of spur and heel forms were circulating, after which the spur forms gradually increased in popularity so that, by the early eighteenth century, they had become the dominant form.

A particular characteristic of the early bowls is the very low incidence of rim milling, which was commonplace across most other parts of the country during the seventeenth century. This fact, combined with distinctive local bowl forms, shows that there must have been well-established production on the island by the middle of the century. Very few of the early pipes are marked or burnished although some have milled stem decoration, including two examples from previous excavations at the castle, one of which has a very elaborate decorative scheme (Brereton 2000, figs 21–22). There is an example from the recent castle

excavations with a criss-cross pattern (Fig. 2, 19), while another example from the Sun Inn site has diagonal bands of milling (Fig. 2, 20). The recent castle example may have been added to help disguise a stem repair, but the Sun Inn example appears to be purely decorative. There is another milled stem from the Sun Inn (Fig. 3, 22) and it is interesting to note that in both cases the milling occurs on pipes with plain rims. This shows that the pipemakers clearly had milling tools but often simply chose not to apply them to the rims of the pipes that they were making.

Around 1700 the use of both incuse stamped stem marks and relief moulded initials on the sides of the heel or spur was quite widely adopted (Fig. 5, 42–51). The stem marks are of a style found across central southern England and show that the island's pipemakers were operating within a broader stylistic tradition. There is a paucity of later eighteenth-century material, reflecting the dip in documented makers, but, from the late eighteenth century

onwards, a wide range of marked and decorated pieces occurs, most of which can be attributed to local makers (Figs 6–12). The makers' initials were often moulded on the sides of the spur or heel and sometimes the full name added to the stem or bowl. The bowl forms and decoration are discussed in more detail within thematic sections below, followed by sections on the marked and traded pipes.

The illustrations are arranged in four groups, each of which is presented in roughly chronological order; the seventeenth to mid-eighteenth century heel forms (Figs 1–3, 1–25); the seventeenth to mid-eighteenth century spur forms (Figs 3–5, 26–51); the late eighteenth century and later marked pipes (Figs 6–10, 52–94) and, finally, unmarked pipes from the late eighteenth century onwards (Figs 11–12, 95–104). Only examples likely to have been made on the island itself are included in this last group.

The material in this catalogue has been drawn from four different sources; finds from the 2006 excavations at Carisbrooke Castle (Nos. 6, 7, 19, 23–24, 26, 30, 36, 38, 41, 44, 46–49, 51, 55, 66, 72, 78–79, 81, 87, 94 and 103); finds from the Isle of Wight museum service collections studied by the author (Nos. 1–2, 8–18, 20, 22, 27–28, 31, 33, 35, 37, 39–40, 50 and 52); pipes from an Isle of Wight reference collection in the possession of the author, at least some of which were collected from the site of the Orchard Street pipe manufactory in Newport (Nos. 3–5, 21, 25, 29, 32, 34, 42–43, 45, 57, 60, 63, 71, 73–77, 82–86, 88–90, 102 and 104) and pipes recovered from the 1978 excavations on the site of the Orchard Street factory (Nos. 53–54, 56, 58–59, 61–62, 64–65, 67–70, 80, 91–93, 95–101). The Orchard Street pipes are also in the museum service collections and selected pieces have been seen briefly by the author, but not studied in detail. The illustrations of the pipes from the 1978 excavations are all taken from an unpublished type series prepared at the time by an unknown illustrator and now held in the Historic Environment Record. All of the other pipes have been drawn and inked by Susie White.

The illustrated pipes are all shown at life size with burnished surfaces being indicated by a light broken line (Fig. 4, 30). Only one pipe has an internal bowl cross, which is shown in

plan as a separate detail (Fig. 9, 79). Each entry ends with the context or accession number for the relevant piece within its respective collection (see above).

*The seventeenth and early eighteenth-century heel forms (Figs 1–3, 1–25)*

The early heel pipes from the castle (Brereton 2000, figs 63.1–3) are broadly of London styles, as is the case with early pipes from across most of the country. This makes it hard to be sure whether they are traded pieces from the mainland or products of early makers on the island itself, particularly since they are almost all unmarked. By the middle of the century, however, local styles had emerged showing that there must have been sufficient makers working on the island for this to have happened. Two examples from the recent castle excavations are characteristic of these types; they have rather baggy, forward leaning bowls, a tendency for the rim to push forward to the front of the bowl and they lack any rim milling (Fig. 1, 6–7).

During the third quarter of the seventeenth century the heel forms have rather variable profiles (Fig. 1, 1–8), sometimes still copying London styles (e.g., Fig. 1, 4), but generally based on the barrel-shaped style that was typical of this period. After around 1670 taller more elongated forms appear, but still with a forward leaning bowl (Figs 1–2, 9–18). Marks remain very rare and, even when they occur, they are sometimes just symbol marks that cannot be linked to a particular maker (but are probably local, e.g., Fig. 2, 13). It is only at the end of the century that a more upright and cylindrical style appears (Fig. 2, 20). This style carries on into the eighteenth century but it continues to have a local feel and a tendency to lean forward (Figs 2–3, 20–23), rather than having the more upright form that was fashionable in London at this time (Fig. 3, 25). These late heel types often have moulded initial or symbol marks on the sides of the heel (Fig. 3, 23–25).

*List of illustrated pipes (Figs 1–3)*

Fig. 1.1 Bowl of c1660–80 with a bottered rim but no milling. Stem bore 6/64". Sun Inn, Newport (IWCAC:1339 LE 1).

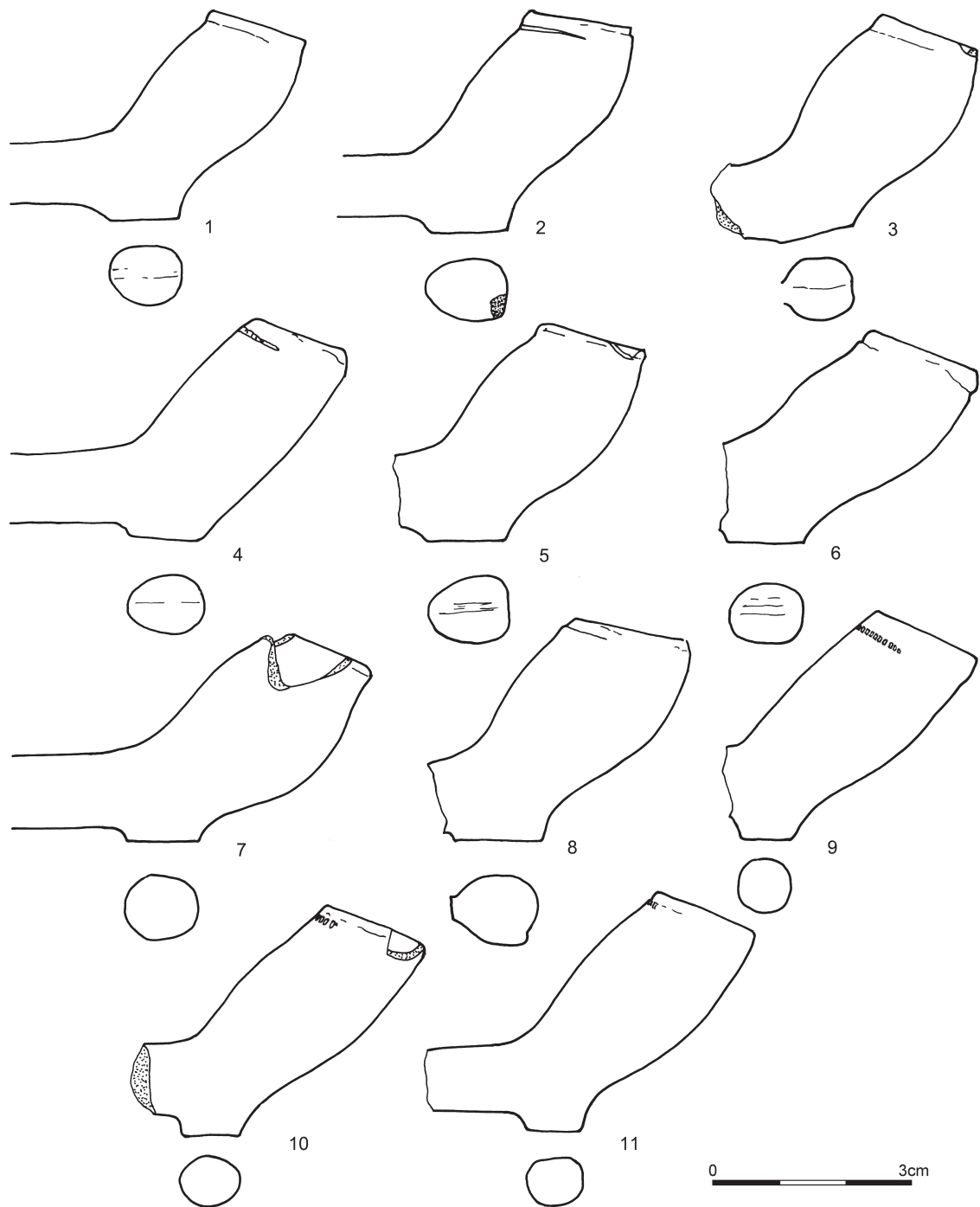

Fig. 1 Seventeenth and early Eighteenth-century heel forms, Nos 1-11

- Fig. 1.2 Bowl of c1660–80 with a bottered rim but no milling. Stem bore 8/64". Sun Inn, Newport (IWCAC:1339 LE 2).
- Fig. 1.3 Bowl of c1660–80 with a bottered rim but no milling. Stem bore 7/64". Unprovenanced find from the Isle of Wight (221007.1).
- Fig. 1.4 Bowl of c1660–80 with a bottered and half milled rim. Stem bore 7/64". Unprovenanced find from the Isle of Wight (221007.4).
- Fig. 1.5 Bowl of c1660–80 with a bottered rim but no milling. Stem bore 6/64". Unprovenanced find from the Isle of Wight (221007.3).
- Fig. 1.6 Bowl of c1660–1680 with a bottered rim but no milling. Stem bore 6/64" (Context 200).
- Fig. 1.7 Bowl of c1660–1680 with a damaged rim, which is bottered but has no surviving milling. Stem bore 6/64" (Context 308–310).
- Fig. 1.8 Bowl of c1670–90 with a bottered and internally trimmed rim but no milling. Stem bore 7/64". Sun Inn, Newport (IWCAC:1339 LE 2).
- Fig. 1.9 Bowl of c1670–1700 with a bottered and internally trimmed rim that has been half milled. Stem bore 8/64". Sun Inn, Newport (IWCAC:1339 LE 3).
- Fig. 1.10 Bowl of c1670–1700 with a bottered rim that has been half milled. Stem bore 7/64". Sun Inn, Newport (IWCAC:1339 LE 3).
- Fig. 1.11 Bowl of c1670–1700 with a bottered rim that has been one quarter milled. Stem bore 8/64". Sun Inn, Newport (IWCAC:1339 LE 9).
- Fig. 2.12 Bowl of c1670–1700 with a bottered rim that has been half milled. Stem bore 7/64". Sun Inn, Newport (IWCAC:1339 LE 17).
- Fig. 2.13 Bowl of c1680–1700 with a bottered rim that has been half milled. Heel stamped with a simple relief symbol mark, most likely representing either a local maker from the island or from an adjoining area of central southern England. Stem bore 7/64". Sun Inn, Newport (IWCAC:1339 LE 11).
- Fig. 2.14 Bowl of c1680–1710 with a bottered rim that has been half milled. Stem bore 6/64". Sun Inn, Newport (IWCAC:1339 LE 12).
- Fig. 2.15 Bowl of c1680–1710 with a bottered and internally trimmed rim that has been half milled. Stem bore 7/64". Sun Inn, Newport (IWCAC:1339 LE 15).
- Fig. 2.16 Bowl of c1680–1710 with a bottered rim but no milling. Stem bore 8/64". Sun Inn, Newport (IWCAC:1339 LE 14).
- Fig. 2.17 Bowl of c1680–1720 with a bottered rim that has been one quarter milled. Stem bore 7/64". Sun Inn, Newport (IWCAC:1339 LE 16).
- Fig. 2.18 Bowl of c1680–1720 with a bottered and internally trimmed rim that has been half milled. The spur does not appear to have moulded properly during manufacture and has been smoothed over while still soft. Stem bore 6/64". Sun Inn, Newport (IWCAC:1339 LE 21).
- Fig. 2.19 Stem fragment of c1640–1700 with milled bands forming a decorative pattern on the stem. Stem bore 8/64" (Context 124).
- Fig. 2.20 Bowl of c1680–1720 with a bottered and internally trimmed rim but no surviving milling. The stem is decorated with a number of diagonal bands of milling. Stem bore 5/64". Sun Inn, Newport (IWCAC:1339 LE 10).
- Fig. 3.21 Bowl of c1690–1740 with a cut and wiped rim, not milled. Stem bore 6/64". Unprovenanced find from the Isle of Wight (221007.14).
- Fig. 3.22 Bowl of c1700–1750 with a cut and internally trimmed rim that has not been milled. Part of a milled band survives at the broken stem junction. Stem bore 6/64". Sun Inn, Newport (IWCAC:1339 LE 7).
- Fig. 3.23 Bowl fragment of c1690–1730 with the relief moulded maker's initials WA on the sides of the heel. Fox & Barton (1986, 188) give an unsourced reference to William Ally being a Newport pipemaker and a William Ally is recorded working at Winchester from c1730–77 (Oswald 1975, 171). An individual named William Alley (occupation unknown) had a son John baptised at Newchurch in 1692, who may well have been the pipemaker John Ally recorded there during the first half of the eighteenth century. If so, then it is possible that both father and son were pipemakers and that this is the William Ally who made this pipe. Bottered rim (no surviving milling) and a stem bore of just over 5/64" (Context 224).
- Fig. 3.24 Bowl fragment of c1700–1750 with a relief moulded symbol mark on either side of the heel (one side partially chipped away). Very similar examples are known from Portsmouth (Fox & Barton 1986, Fig. 120.88). Stem bore 6/64" (Context 310).
- Fig. 3.25 Bowl of c1700–1760 with a bottered cut rim, not milled, and the relief moulded maker's initials SW on the sides of the heel. There is no known maker with these initials recorded for the Isle of Wight. Stem bore just over 5/64". Unprovenanced find from the Isle of Wight (221007.11).

*The seventeenth and early eighteenth-century spur forms (Figs 3–6, 26–51)*

Some early seventeenth-century spur forms of general London style have been found



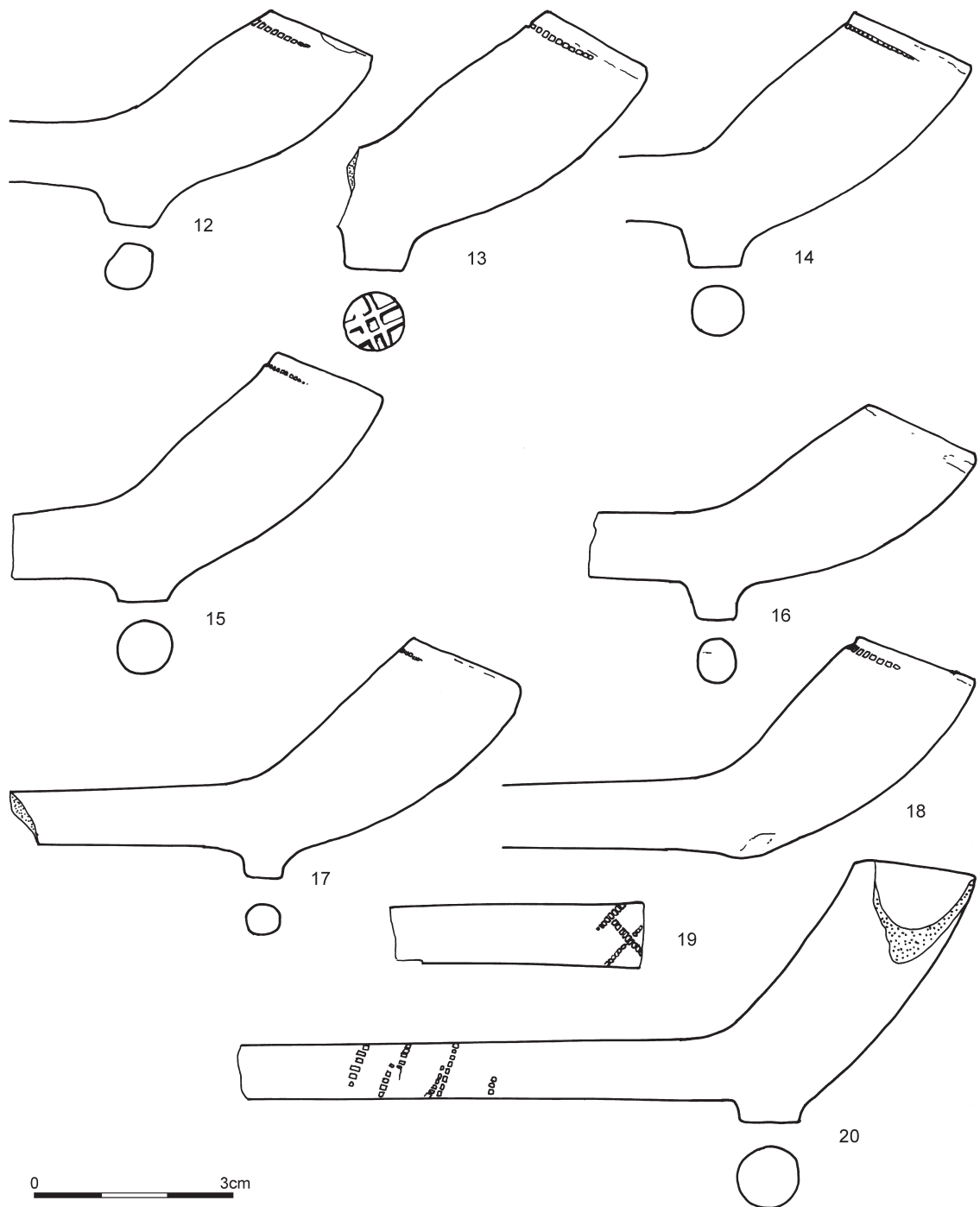

Fig. 2 Seventeenth and early Eighteenth-century heel forms, Nos 12-20

elsewhere in the castle (Brereton 2000, fig. 63.4), but the earliest piece from the 2006 and 2008 excavations dates from c1650–80 (Fig. 3, 26). This example has a damaged rim but is of an unusual forward leaning form that was probably produced locally. Other late seventeenth-century spur forms from the island are generally of London styles (Fig. 3, 27–31) although some have more pronounced local characteristics, such as a forward leaning and poorly trimmed bowl from Orchard Street (Fig. 3, 28) and most were almost certainly produced locally. As with the heel forms, many of these bowls are not milled at the rim. One example from the castle excavations is neatly made and has a good burnish, suggesting that it was a more expensive item, although the lack of rim milling again points to local production (Fig. 3, 30).

As with the heel forms, there is a marked change of style at the end of the century with the introduction of rather more slender, elegant forms (Fig. 4, 32–35), some of which are particularly large (Fig. 4, 35). In broad terms these forms still mirror London styles but, alongside them, more regional styles with slightly more upright forms, rims more nearly parallel with the stem and sometimes a distinctive constriction just below the rim were being produced (Fig. 4, 36–40). These forms also tend to have longer, thinner spurs, a characteristic that became particularly pronounced during the course of the eighteenth century, as is shown by an example from the castle (Fig. 4, 41).

Other local characteristics not typical of London pipes are the use of stem stamps (Fig. 5, 42–45 & 48) and the fairly frequent use of moulded initials on the sides of the spur (Fig. 5, 46–7 & 49–51). Many of the marks found at Carisbrooke can be identified with local makers and so it is clear that the majority of these pipes were being sourced locally for the castle. During the first half of the eighteenth century the spur bowls became large and thinner but invariably with the distinctive features that are characteristic of pipes from central southern England at this period; a marked bulge on the lower part of the profile facing the smoker and a slight constriction below the rim itself (e.g., Figs 4–5, 39 & 45). Almost all of the bowls produced

before c1760 were plain, although the London fashion for armorial pipes depicting the Hanoverian Arms does appear to have been adopted by John Ally from around the middle of the eighteenth century (Trott 2001, 49–50).

*List of illustrated pipes (Figs 3–6)*

- Fig. 3.26 Damaged spur pipe of c1650–1680 with an unusual bowl form; no surviving rim. Stem bore just over 7/64" (Context 205).
- Fig. 3.27 Bowl of c1660–90 with a bottered and internally trimmed rim but no milling. Stem bore 7/64". Sun Inn, Newport (IWCAC:1339 LE 4).
- Fig. 3.28 Bowl of c1660–1690 with a bottered rim but no milling. Stem bore 6/64". Orchard Street, Newport (IWCAC:1543.1.18).
- Fig. 3.29 Bowl of c1660–90 with a bottered and fully milled rim. Very smooth glossy finish to the pipe, but not burnished. Stem bore 7/64". Unprovenanced find from the Isle of Wight (221007.6).
- Fig. 3.30 Bowl of c1660–1690 with a bottered and internally trimmed rim. The pipe has been given a good but rather light burnish, leaving a neat glossy finish. No milling. Stem bore 7/64" (Context 224).
- Fig. 3.31 Bowl of c1670–1700 with a bottered and internally trimmed rim but no milling. Stem bore 7/64". Sun Inn, Newport (IWCAC:1339 LE 4).
- Fig. 4.32 Bowl of c1680–1710 with a bottered and three-quarters milled rim. Stem bore 6/64". Unprovenanced find from the Isle of Wight (221007.8).
- Fig. 4.33 Bowl of c1690–1720 with a bottered rim but no milling. Stem bore 7/64". Sun Inn, Newport (IWCAC:1339 LE 16).
- Fig. 4.34 Bowl of c1690–1720 with a bottered rim but no milling. Stem bore just over 6/64". Unprovenanced find from the Isle of Wight (221007.12).
- Fig. 4.35 Large bowl of c1690–1710 with a bottered rim but no milling. Stem bore 7/64". Unprovenanced find from the Isle of Wight (221007.10).
- Fig. 4.36 Bowl of c1680–1720 with a damaged rim that has been bottered and milled. Stem bore 5/64" (Context 124).
- Fig. 4.37 Bowl of c1690–1730 with a bottered rim, half milled. Stem bore 7/64". Sun Inn, Newport (IWCAC:1339 LE 13).
- Fig. 4.38 Bowl of c1690–1730 with a damaged rim

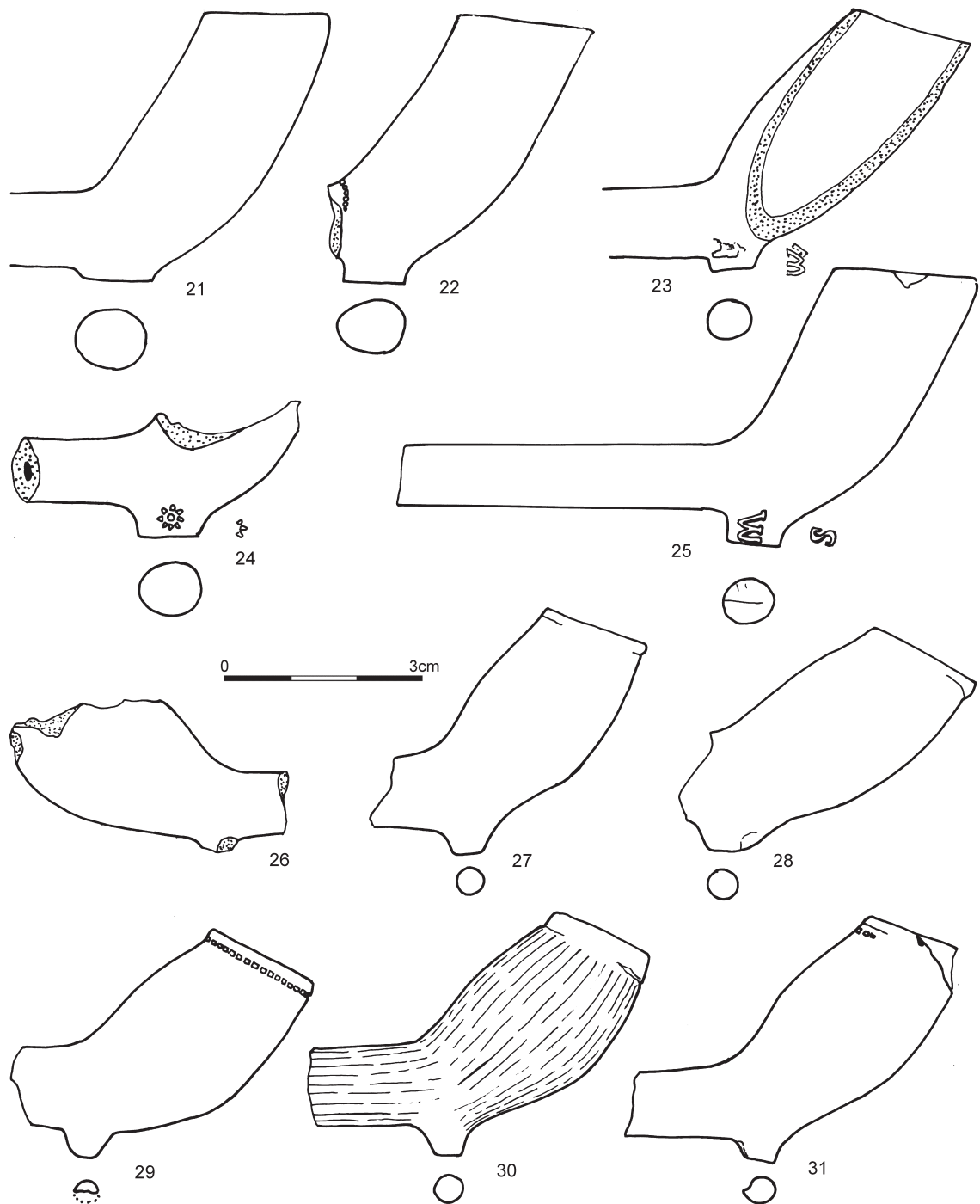

Fig. 3 Seventeenth and early Eighteenth-century heel forms, Nos 21–25; Seventeenth and early Eighteenth-century spur forms, Nos 26–31

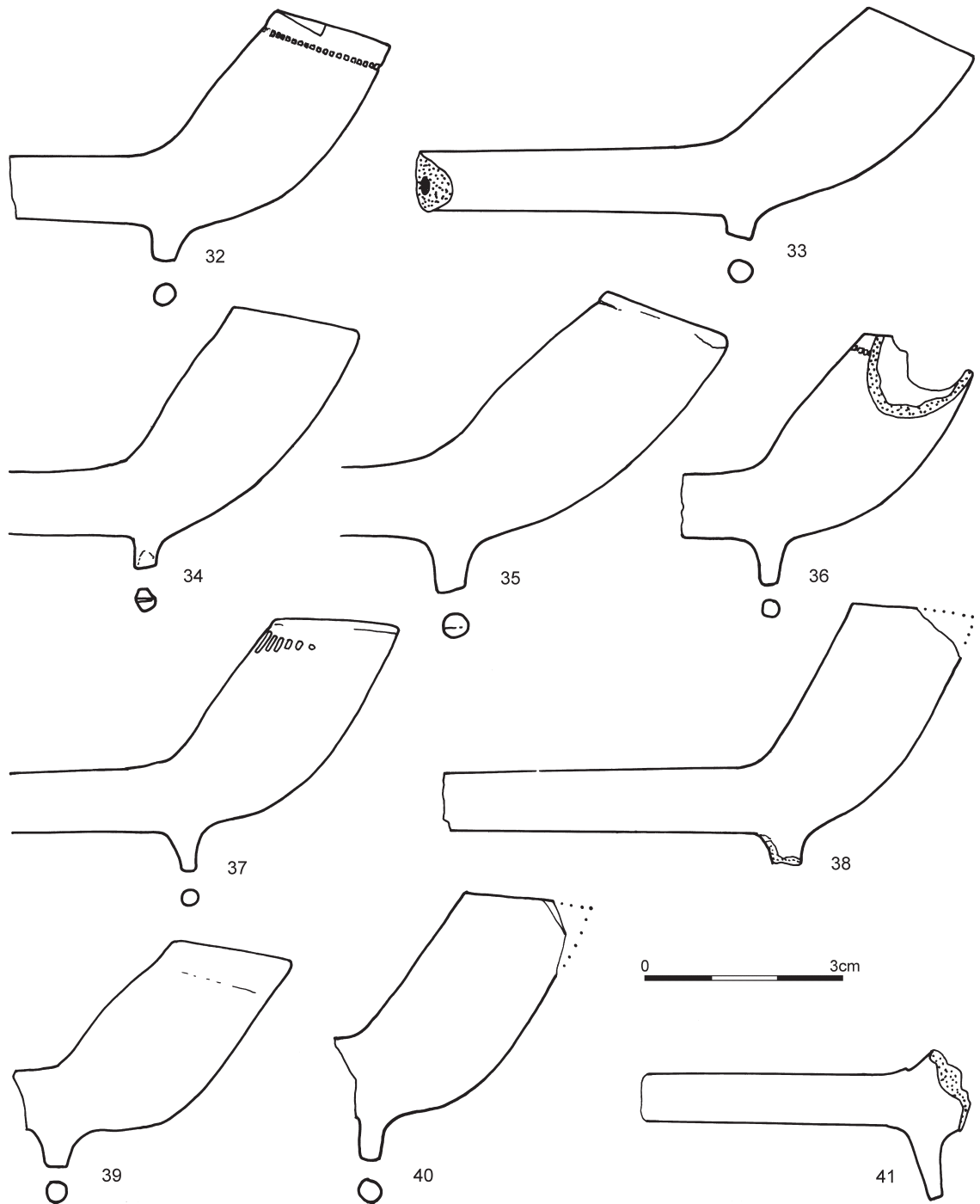

Fig. 4 Seventeenth and early Eighteenth-century spur forms, Nos 32–41

- that has been cut; no surviving milling. Stem bore just over 5/64" (Context 124).
- Fig. 4.39 Bowl of c1690–1730 with a bottered rim but no milling. There is a faint mould line near the rim where it has been repaired or altered. Stem bore 5/64". Sun Inn, Newport (IWCAC:1339 LE 5).
- Fig. 4.40 Bowl of c1690–1740 with a cut rim that has not been milled. Stem bore 7/64". Rock Roman Villa (PRN:277.58.10, Small Find 33, RC).
- Fig. 4.41 Bowl fragment of c1740–1800 with an unusually long and fine spur, the tip of which has been chipped off. Stem bore 4/64" (Context 301).
- Fig. 5.42 Stem fragment of c1700–1750 with an incuse stamped maker's mark across the stem reading IOHN / ALLY above crossed pipes. John Ally is recorded working in Newport from at least 1730–47. The stem has a naturally glossy surface (but is not burnished) and a stem bore of 5/64". Unprovenanced find from the Isle of Wight (221007.16).
- Fig. 5.43 Stem fragment of c1700–1750 with a simply executed relief stamped star mark across the stem. Stem bore 5/64". Unprovenanced find from the Isle of Wight (221007.18).
- Fig. 5.44 Bowl fragment of c1700–1750 with an incuse stamped maker's mark across the stem reading IOHN / STEP / HENS. This particular die is distinctive in that the 'N' of 'IOHN' is retrograde and the T and E of 'STEPHENS' are ligatured together. A more complete impression of this die type is illustrated by Walker from a 1740s context at Louisbourg (1967, Fig. 3), which shows that in the last line the H and the E would also have been ligatured together and that the final N would have been retrograde too. There appear to have been two pipemakers named John Stephens working in Newport between at least 1708 and 1751. Stem bore 6/64" (Context 124).
- Fig. 5.45 Bowl of c1710–1750 with an incuse stamped maker's mark across the stem reading IOHN / STEP / HENS. There appear to have been two pipemakers named John Stephens working in Newport between at least 1708 and 1751. The bowl has a cut rim and a mould line running below it, which suggests a repair or alteration of the mould. Stem bore just over 5/64". Unprovenanced find from the Isle of Wight (221007.15).
- Fig. 5.46 Bowl fragment of c1700–1750 with the relief moulded maker's initials IS on the sides of the spur for John Stephens. There appear to have been two pipemakers named John Stephens working in Newport between at least 1708 and 1751. Stem bore 6/64" (Context 124).
- Fig. 5.47 Bowl fragment of c1700–1750 with the relief moulded maker's initials IS on the sides of the spur for John Stephens. There appear to have been two pipemakers named John Stephens working in Newport between at least 1708 and 1751. Stem bore 6/64" (Context 124).
- Fig. 5.48 Stem fragment of c1700–1740 with an incuse stamped mark reading RICH / STEP / HENS for Richard Stephens, a Newport maker who took apprentices in 1719 and 1720. There are also circular stem stamps marked R / STEP / HENS known from Newport (Trott 2001, Figs 6.15–16). Stem bore 5/64" (Context 224).
- Fig. 5.49 Bowl fragment of c1700–1740 with the relief moulded initials RS on the sides of the spur for Richard Stephens, a Newport maker who took apprentices in 1719 and 1720. No surviving rim. Stem bore 6/64" (Context 205).
- Fig. 5.50 Bowl of c1700–1740 with a cut rim that has possibly been wiped but not milled. Relief moulded RS mark on the spur for Richard Stephens of Newport, recorded working in 1719 and 1720. Stem bore 4/64". Sun Inn, Newport (IWCAC:1339 LE 18).
- Fig. 5.51 Bowl fragment of c1700–1750 with the relief moulded maker's initials WG on the sides of the spur. There is no known maker with these initials on the island. Cut rim and a stem bore of 6/64" (Context 140).

*The late eighteenth century and later pipes (Figs 6–12, 52–104)*

By the end of the eighteenth century pipe styles had changed completely and moulded decoration had suddenly become almost universal. Fluted designs were popular from the 1760s onwards and there is an unusual early form with wavy flutes made by Coster of Fareham that has been found at the Sun Inn site in Newport (Fig. 6, 52). Imported pieces from the mainland were found at the castle excavations too, for example, the spur with a surname initial F that was almost certainly made by one of the Frost family, who were working in the Southampton/Portchester area (Fig. 6, 55). Other marked and decorated pipes occur on the island that cannot be identified with any known maker, for example a fluted IB bowl and a Britannia bowl with the surname initial

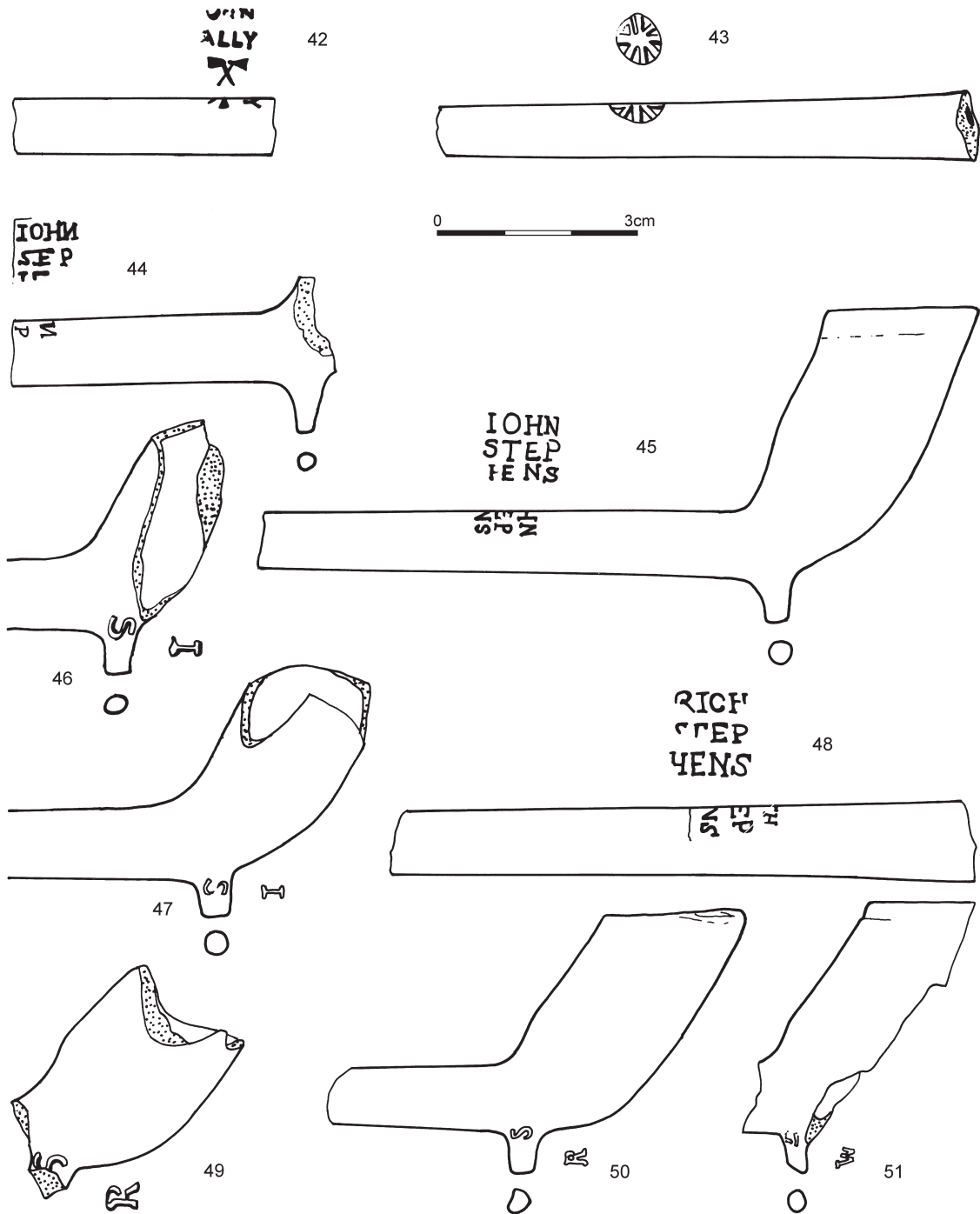

Fig. 5 Seventeenth and early Eighteenth-century spur forms, Nos 42-51

R (Fig. 6, 53–54). These two pieces came from the Orchard Street kiln site in Newport and so could even have been made there, since little is known about the site before the 1830s. At that time the site was almost certainly being run by John Jones, since the 1841 census lists him in Orchard Street and pipes recovered there were marked II (e.g., Fig. 6, 56–59). Jones was, however, aged 80 in 1841 and it is not known how long he had been a master pipemaker before that date and whether other individuals had operated the Orchard Street site before him. There is an 1827 reference to a pipe kiln in Cosham Street, which could either have been a precursor to the Orchard Street site a rival to it (see entry for Richard Mayne (I) in Appendix 1). The Cosham Street reference is particularly interesting since the kiln seems to have been built without any associated dwelling on an odd shaped piece of land with a street frontage of only 13ft 6ins.

Although the early history of the Orchard Street site and the origin/makers of the early marked pipes found there are unclear, it went on to become the dominant pipemaking site on the island until well into the twentieth century. The pipes made by Jones (Fig. 6, 56–59) included plain bowls, fluted bowls and a pipe decorated with a rose and thistle motif, which was a very popular design at this period, and one that was also made by a number of makers in the Portsmouth Harbour area (Fox & Hall 1979 and this report, Fig. 6, 60). Fluted pipes were one of the most common styles found in the south of the country and during this period they were usually decorated either with parallel lines that alternated between thick and thin (Fig. 6, 53 & 57) or were of uniform thickness (Fig. 6, 58). Fluted bowls have previously been found at the castle (Brereton 2000, fig. 64.30) and there are five fluted bowl fragments amongst the recently excavated assemblage, showing that this style was regularly used on the site.

By 1839 the Orchard Street works had been taken over by Robert Cole, who would then have been only about 22 years old. He was clearly a successful businessman and, twelve years later, the 1851 census records that he was a tobacco pipe maker and cider merchant employing 6 men, 2 boys and 2 women. By 1861

he is described as a cabinet maker employing 4 men and 4 apprentices as well as a pipemaker employing 4 men and 1 boy. He tried to lease out the pipemaking business in 1870 and in 1871 was listed in the census as an auctioneer and cabinet maker employing 2 men and 2 boys. The attempt to lease the pipe works appears to have been unsuccessful since he was demonstrating pipemaking at an exhibition in 1874 and continued to be listed as a pipemaker in trade directories. In the 1881 census he was once again described as a tobacco pipe manufacturer, then employing 4 men and 1 woman. The returns for 1891 and 1901 describe him as a retired farmer, showing that he clearly had various business interests throughout his life. The most constant trade, however, was the pipe works, which he ran from c1839 until the 1880s, generally employing about 5 people at it. This suggests that it would have been a substantial works, capable of manufacturing considerable numbers of pipes, as witnessed by their widespread occurrence across the island as well as by coastal exports, with his pipes having been found in considerable numbers in Torbay (Coleman 2013, 20–21). Pipes from Cole's workshop were by far the most common of any manufacturer found in the recent castle excavations, with as many as 11 examples being represented, and others have been found there previously (Brereton 2000, fig. 64.15)

Cole produced a wide range of pipes, most of which appear to have been marked with his name or initials (Figs 7–9, 61–81). The earlier styles are those with serif lettering and these tend to have larger bowls, more ornate decoration and, sometimes, stem decoration as well (Figs 7–8, 61–70). There are at least three different designs featuring the rose and thistle motif (Fig. 7, 61 & 63–64), the latter two of which also include shamrock leaves and his name in a banner beneath the decoration. A similar design features an ear of barley and, possibly, hops (Fig. 7, 62). A similar unmarked example (but which may have originally had his name on the stem) is also likely to be by Cole (Fig. 11, 95).

Another popular style that Cole produced featured a bottle and glass within a wreath (Fig. 8, 65). This example has his initials on the heel but there are also two other examples with stars

on the heel that were almost certainly made by Cole as well (Fig. 11, 96–97). These are probably the three versions noted by Coleman from the Torbay area (2013, 21). Pipes of this style were also popular amongst makers in the Portsmouth Harbour region (Fox & Hall 1979), as well as further afield.

Cole's later products tend to be less ornately decorated, with slightly squatter and more rounded bowl forms and, usually, sans-serif lettering (Figs 8–9, 72–81). The leaves on the seams become smaller and less deeply serrated (sometimes they were just depicted in outline) and some of the forms have moulded milling at the rim. These changes are in keeping with regional/national trends and show that Cole was keeping abreast of the latest fashions with his products. One of his designs (Fig. 9, 81) had a particularly thin stem that would probably have been a little longer than the ordinary short-stemmed 'cutty' pipes. These pipes were known as 'straws' and were regarded as a better class of pipe that generally sold for rather more than the cutties. Three examples made in this mould were recovered from the recent castle excavations.

Cole probably retired during the 1880s, most likely about 1885, and the business was taken over by James Dyer. Dyer had been born in Carisbrooke in about 1833 but spent much of his adult life in Portsmouth, where he was working as a brewer in 1861 and 1871 and as a stonemason in 1881. He died in 1899 aged 66, having only run the pipeworks for a relatively short time. Despite this, his products are regularly found, suggesting that he continued to run the business on a considerable scale.

The pipes Dyer produced (Figs 9–10, 82–88) are very similar to the later Cole products in profile, i.e., they generally have a rather dumpy rounded form. They also have small neatly formed leaves on the seams, often with an open centre, and the spurs are marked with small sans-serif initials. Dyer did, however, make a greater use of moulded rim milling and he brought back a wider range of decorative motifs for the bowl. Some of these were based on the earlier designs used by Cole, for example a fluted design (Fig. 9, 82) and a bottle and glass motif, but without the wreath (Fig. 9, 83). It is, however, the new designs

introduced by Dyer that are perhaps the most striking; an RAOB design for the Royal Antediluvian Order of Buffaloes (Fig. 9, 84), an AOF design for the Ancient Order of Foresters (Fig. 10, 85) and a footballers design (Fig. 10, 86). Dyer may well also have been responsible for the distinctive cyclist design (Fig. 12, 102) and the two different claw designs produced to commemorate the 1887 jubilee (Fig. 12, 103–104). None of these designs were unique to Dyer, for example, a very similar cyclist pipe was made by Henry Leigh of Portchester (Fox & Hall 1979, fig. 81), but they clearly show that he was changing and developing the product range of the business, rather than letting it stagnate. Three or four pipes made by Dyer were recovered from the recent castle excavations, and others have been found there previously (Brereton 2000, Fig. 64.32).

Following Dyer's death in 1899 the business was taken over by Leonard Andrews, probably in about 1903. Like Dyer, Andrews did not come from a pipemaking background. He was born in Winchester in 1873 but had moved to Carisbrooke by 1891, when he was working as a bank clerk. In 1901 he was in Cambridgeshire working as an estate agents cashier and accountant and so it appears that he came to the business as an owner/manager rather than an experienced pipemaker. By the time of the 1911 census he was described as a manufacturer of fire-clay and pipe-clay, living at 18 Orchard Street, Carisbrooke, which was also the address of the pipeworks.

It is not known how long the business continued under Andrews and only two examples of his pipes are known for sure. These are both marked with incuse moulded lettering along the stem and are of typical early twentieth-century designs. One example has conical spikes on the stem, and is part of a 'thorn' pipe (Fig. 10, 89), while the other has a taller and rather larger, more upright, bowl than those produced by Dyer and with a ribbon like stylised leaf design on the seams (Fig. 10, 90). There are, however, unmarked bowls from the island that may well have been produced by Andrews during this period. These include examples with rusticated (wood effect) surfaces, a range of RAOB designs, a bowl with the King's head on the front, pre-



sumably produced for the coronation of either Edward VII or George V, and a large Irish style bowl with a castle gateway on the front. This last design has been found at a number of different sites on the island, including at Carisbrooke castle itself (Brereton 2000, fig. 64.33). There is also a pipe with the bowl modelled as a head of a guardsman in Carisbrooke Castle Museum that was purchased in Newport in 1912 and said to have been made by Andrews (D.1986.2896.106).

Like both Dyer and Cole before him, Andrews would have had to compete with imports to the island from a variety of sources. Pipes from neighbouring coastal areas certainly found their way to the island, particularly the products of Henry Leigh of Portchester, who founded a business in about 1840 that continued until about 1932 (Fox & Hall 1979, 18–19). Pipes from this firm are particularly common on the island (e.g., Fig. 10, 91–92). Bottle dumps near Newport are known to have produced a number of French pipes, notably several examples of a greyhound and hunting horn design that was produced by the firm of Dumeril, while the castle excavations produced three stems with incuse stamped stem marks for the firm of W. Southorn & Co from Broseley in Shropshire. This mark was used by the firm from around 1850 until they closed in about 1960 (Higgins 1987). Southorn's specialised in making long-stemmed churchwarden pipes that always sold for considerably more than the ordinary cutty pipes. The presence of these marks at the castle shows that good quality imported pipes were finding a place there amongst the locally produced pieces from Orchard Street.

*List of illustrated pipes (Figs 6–12)*

- Fig. 6.52 Bowl fragment of c1770–1800 with a cut rim. Unusual 'wavy' flutes with the relief moulded maker's name COSTER / FAREHAM incorporated between them. Arthur Coster was born in 1752 and died in 1816 (Fox & Hall 1979, 20). Sun Inn, Newport (IWCAC:1339 LE 20).
- Fig. 6.53 Fluted bowl of c1780–1830 with the relief moulded maker's initials IB on the sides of the heel. No known maker with these initials on the Isle of Wight. (Orchard Street Excavations; I.W.C.A.C. PRN. 1543:14:2).
- Fig. 6.54 Damaged bowl of c1810–1850 depicting Britannia with the relief moulded maker's initial R on the right hand side of the heel (Orchard Street Excavations; I.W.C.A.C. PRN. 1543:14:2).
- Fig. 6.55 Bowl fragment of c1800–1880 with relief moulded maker's initials on the sides of the spur. The initials probably read IF, although they are slightly unclear and EF, LF or TF are other possibilities. If the initials IF are correct, the most likely maker is James Frost of Portchester (born 1743, died 1827; Fox & Hall 1979, 28). If they are TF then the maker could be Thomas Frost of Southampton, recorded from at least 1804–43 (Oswald 1975, 172). There are traces of leaf decoration on the bowl seams. Stem bore 5/64" (Context 308–310).
- Fig. 6.56 A large thin-walled bowl of c1790–1830 with the relief moulded maker's initials II or ID on the sides of the heel with stars above. Most likely maker is John Jones of Newport, recorded working from at least 1832–41 (but aged 80 in 1841 and so likely to have been working from around 1780 onwards). (Orchard Street Excavations; I.W.C.A.C. PRN. 1543:2:24).
- Fig. 6.57 Bowl of c1780–1830 with a cut rim. The bowl is decorated with flutes and has the relief moulded initials II on the sides of the heel for John Jones, a Newport pipemaker recorded working from at least 1832–41 (but aged 80 in 1841 and so likely to have been working from around 1780 onwards). The mould halves are poorly aligned causing a 'step' in the base of the heel, which has not been trimmed. Stem bore 5/64". Unprovenanced find from the Isle of Wight (221007.20).
- Fig. 6.58 Fluted bowl of c1800–1840 with the relief moulded initials II on the sides of the heel for John Jones, a Newport pipemaker recorded working from at least 1832–41 (but aged 80 in 1841 and so likely to have been working from around 1780 onwards). (Orchard Street Excavations; I.W.C.A.C. PRN. 1543:1:5).
- Fig. 6.59 Rose and thistle bowl of c1800–1840 with the relief moulded initials II on the sides of the heel for John Jones, a Newport pipemaker recorded working from at least 1832–41 (but aged 80 in 1841 and so likely to have been working from around 1780 onwards). (Orchard Street Excavations; I.W.C.A.C. PRN. 1543:0:0).
- Fig. 7.60 Bowl with a rose and thistle design and the maker's initials RG for Richard Goodall of Gosport, who is recorded working from at least 1841–67 (Fox & Hall 1979, 21). Fox and Hall also illustrate this design (fig. 18.124)

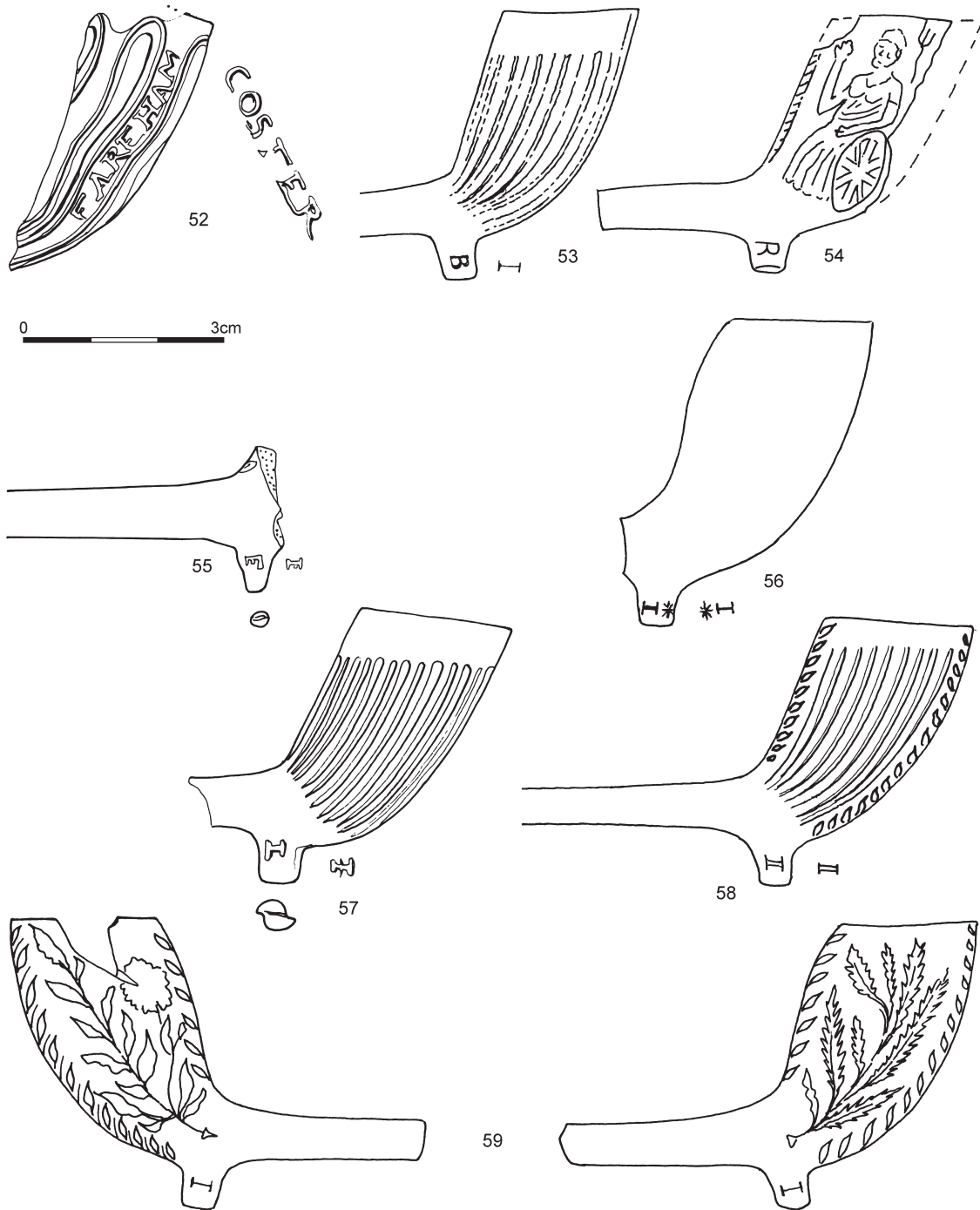

Fig. 6 Late Eighteenth-century and later pipes, Nos 52–59

- and note that the pipe was a churchwarden style, the mould for which survives in Portsmouth Museum. Stem bore just over 5/64". Unprovenanced find from the Isle of Wight (221007.22).
- Fig. 7.61 A large bowl with a rose and thistle design and the maker's initials RC (for Robert Cole) relief moulded on the sides of the spur. There are also relief-moulded dots around the rim of the bowl. Cole operated the pipe works in Orchard Street, Newport from c1839–1885. (Orchard Street Excavations; I.W.C.A.C. PRN. 1543:1:3).
- Fig. 7.62 Bowl with plant decoration including an ear of barley on the left hand side and, possibly, hops on the right. There are also the maker's initials RC (for Robert Cole) relief moulded on the sides of the spur. This example has fired clay adhering to the bowl, suggesting that it is a waste piece that was once incorporated into a pipe kiln muffle. Robert Cole operated the pipe works in Orchard Street, Newport from c1839–1885. (Orchard Street Excavations; I.W.C.A.C. PRN. 1543:1:22).
- Fig. 7.63 Bowl with rose, thistle and shamrock decoration on each side and the maker's name R. COLE / NEWPORT relief moulded in a banner beneath (same design on both sides). Robert Cole operated the pipe works in Orchard Street, Newport from c1839–1885. This example has smears of fired clay adhering to the bowl and may well represent kiln waste collected from the Orchard Street site. Stem bore 5/64". Unprovenanced find from the Isle of Wight (221007.23).
- Fig. 7.64 Bowl with rose, thistle and shamrock decoration on each side and the maker's name R. COLE / NEWPORT relief moulded in a banner beneath (same design on both sides). Robert Cole operated the pipe works in Orchard Street, Newport from c1839–1885. This example is slightly different to No. 63 above and was made in a different mould. (Orchard Street Excavations; I.W.C.A.C. PRN. 1543:1:6).
- Fig. 8.65 Bowl with a glass and bottle design and the relief moulded initials RC (for Robert Cole) on the sides of the heel. The stem is decorated with stylised leaves and dots (*cf.* No. 66 from the castle excavations, which may well be from a pipe of this type). Cole operated the pipe works in Orchard Street, Newport from c1839–1885. (Orchard Street Excavations; I.W.C.A.C. PRN. 1543:1:9)
- Fig. 8.66 Stem fragment of c1830–1880 with stylised leaf and dot decoration. Similar decoration is known to have been used by Robert Cole, who operated the pipe works in Orchard Street, Newport from c1839–1885 and this is likely to be from one of his pipes (*cf.* No. 65). Stem bore just over 4/64" (Context 200).
- Fig. 8.67 Bowl fragment with foliage decoration and the relief moulded maker's name R. COLE / NEWPORT on the sides of the stem. Cole operated the pipe works in Orchard Street, Newport from c1839–1885. (Orchard Street Excavations; I.W.C.A.C. PRN. 1543:10:8).
- Fig. 8.68 Stem fragment with the relief moulded maker's name R. COLE NEWPORT on both sides of the stem. Cole operated the pipe works in Orchard Street, Newport from c1839–1885. (Orchard Street Excavations; I.W.C.A.C. PRN. 1543:14:13).
- Fig. 8.69 Bowl with fluted decoration and the relief moulded initials RC (for Robert Cole) on the sides of the heel. Cole operated the pipe works in Orchard Street, Newport from c1839–1885. (Orchard Street Excavations; I.W.C.A.C. PRN. 1543:1:1).
- Fig. 8.70 Bowl with fluted decoration and the relief moulded initials RC (for Robert Cole) on the sides of the heel. Cole operated the pipe works in Orchard Street, Newport from c1839–1885. (Orchard Street Excavations; I.W.C.A.C. PRN. 1543:1:1).
- Fig. 8.71 Bowl with a fluted design and the maker's initials RC (for Robert Cole) relief moulded on the sides of the spur. Cole operated the pipe works in Orchard Street, Newport from c1839–1885. Stem bore 5/64". Unprovenanced find from the Isle of Wight (221007.29).
- Fig. 8.72 Bowl fragment with a fluted design and the maker's initial R moulded upright on a shield-shaped backing on the left hand side of the spur (the other side is broken away). Most likely part of an RC pipe made by Robert Cole, who operated the pipe works in Orchard Street, Newport from c1839–1885. Stem bore 5/64" (Context 124).
- Fig. 8.73 Bowl with leaf decorated seams and the maker's initials RC (for Robert Cole) relief moulded on the sides of the spur. Cole operated the pipe works in Orchard Street, Newport from c1839–1885. Stem bore 3/64". Unprovenanced find from the Isle of Wight (221007.30).
- Fig. 8.74 Bowl with leaf decorated seams and the maker's initials RC (for Robert Cole) relief moulded on the sides of the spur. Cole operated the pipe works in Orchard Street,

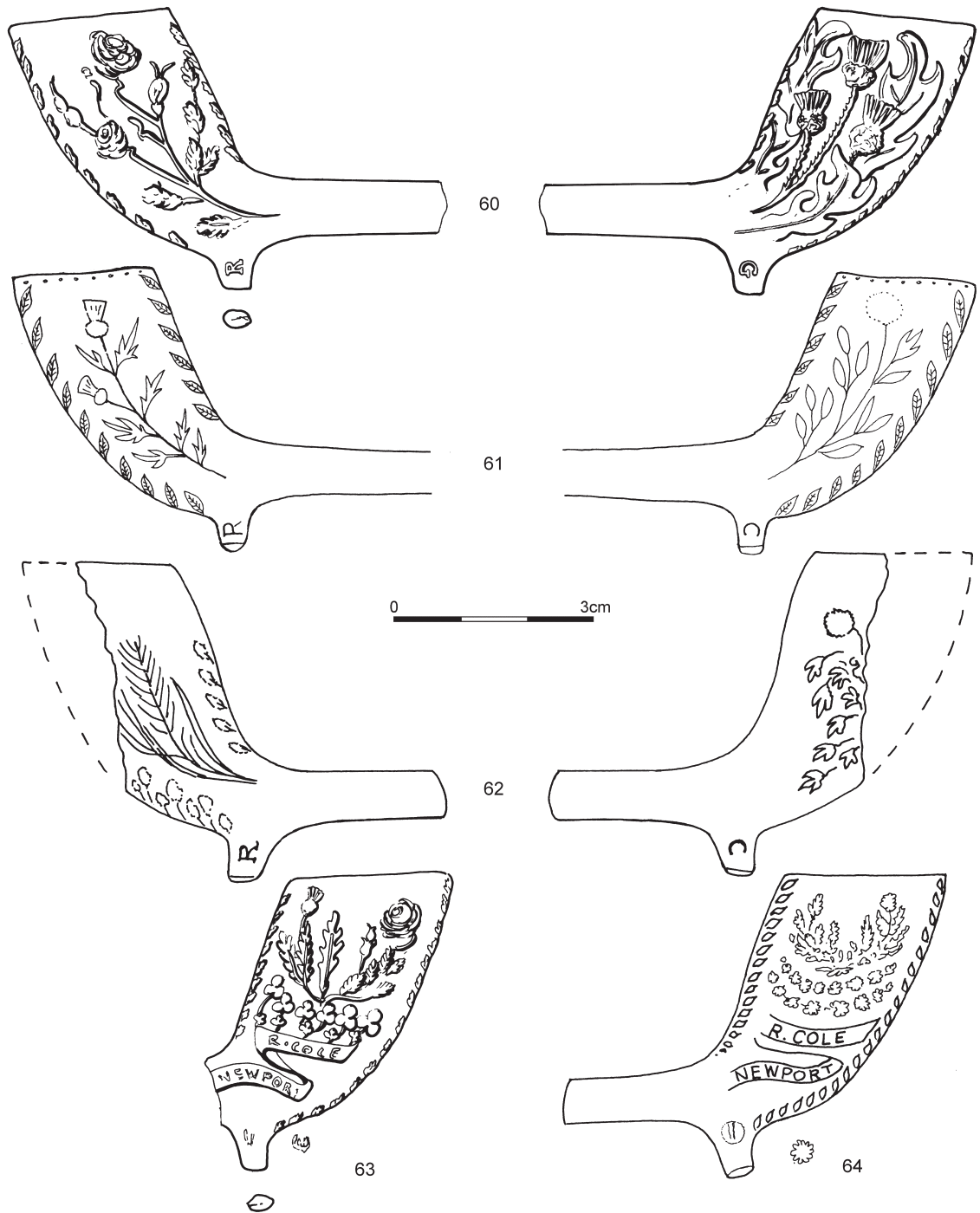

Fig. 7 Late Eighteenth-century and later pipes, Nos 60–64

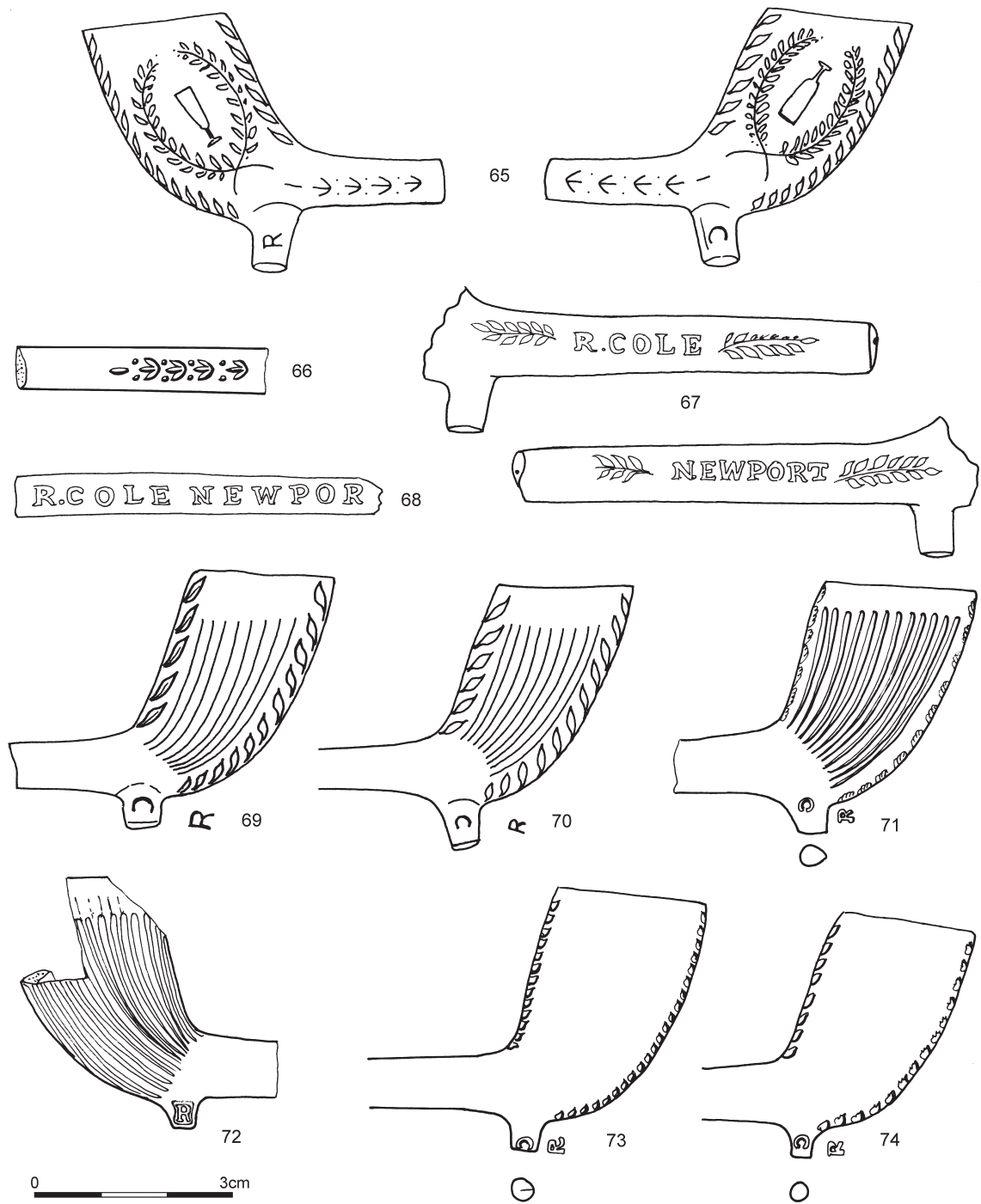

Fig. 8 Late Eighteenth-century and later pipes, Nos 65-74

- Newport from c1839–1885. Stem bore 4/64". Unprovenanced find from the Isle of Wight (221007.36).
- Fig. 9.75 Bowl with leaf decorated seams and the maker's initials RC (for Robert Cole) relief moulded on the sides of the spur. Cole operated the pipe works in Orchard Street, Newport from c1839–1885. Stem bore 4/64". Unprovenanced find from the Isle of Wight (221007.24).
- Fig. 9.76 Bowl with leaf decorated seams and the maker's initials RC (for Robert Cole) relief moulded on the sides of the spur. Cole operated the pipe works in Orchard Street, Newport from c1839–1885. Stem bore 4/64". Unprovenanced find from the Isle of Wight (221007.27).
- Fig. 9.77 Bowl with leaf decorated seams and the maker's initials RC (for Robert Cole) relief moulded on the sides of the spur. Cole operated the pipe works in Orchard Street, Newport from c1839–1885. Stem bore just over 4/64". Unprovenanced find from the Isle of Wight (221007.34).
- Fig. 9.78 Bowl fragment with leaf decorated seams and the maker's initials CR relief moulded on the sides of the spur; probably cut back to front in error for Robert Cole. Cole operated the pipe works in Orchard Street, Newport from c1839–1885. Stem bore unmeasurable (Context 308).
- Fig. 9.79 Bowl with leaf decorated seams and the maker's initials CR (for Robert Cole) relief moulded on the sides of the heel. Cole operated the pipe works in Orchard Street, Newport from c1839–1885. Stem bore 5/64" (Context 224).
- Fig. 9.80 Bowl with leaf seams and the relief moulded initials RC (for Robert Cole) on the sides of the heel as well as R. COLE NEWPORT moulded in very small letters on the right hand side of the stem only. Cole operated the pipe works in Orchard Street, Newport from c1839–1885. (Orchard Street Excavations; I.W.C.A.C. PRN. 1543:3:9).
- Fig. 9.81 Bowl with moulded milling and the maker's initials CR (for Robert Cole) relief moulded on the sides of the spur. This design has a very thin stem (a 'straw' pipe), which was generally a little more expensive than the common 'cutty' clays and considered to be a better class of pipe. Another damaged example, almost certainly from the same mould, was recovered from context 306. Cole operated the pipe works in Orchard Street, Newport from c1839–1885.
- Very thin stem with a bore of 3/64" (Context 100).
- Fig. 9.82 Bowl with a fluted design and the maker's initials JD (for James Dyer) relief moulded on the sides of the heel. Dyer operated the pipe works in Orchard Street, Newport from c1885–1900. Stem bore 5/64". Unprovenanced find from the Isle of Wight (221007.45).
- Fig. 9.83 Bowl with a bottle and glass design and the maker's initials JD (for James Dyer) relief moulded on the sides of the heel. Dyer operated the pipe works in Orchard Street, Newport from c1885–1900. Stem bore 5/64". Unprovenanced find from the Isle of Wight (221007.46).
- Fig. 9.84 Bowl with an RAOB (Royal Antediluvian Order of Buffaloes) design and the maker's initials JD (for James Dyer) relief moulded on the sides of the heel. Dyer operated the pipe works in Orchard Street, Newport from c1885–1900. Stem bore just over 5/64". Unprovenanced find from the Isle of Wight (221007.40).
- Fig. 10.85 Bowl with an Ancient Order of Foresters (AOF) design and the maker's initials JD (for James Dyer) relief moulded on the sides of the heel. Dyer operated the pipe works in Orchard Street, Newport from c1885–1900. Stem bore 5/64". Unprovenanced find from the Isle of Wight (221007.48).
- Fig. 10.86 Bowl with a footballers design and the maker's initials JD (for James Dyer) relief moulded on the sides of the heel. Dyer operated the pipe works in Orchard Street, Newport from c1885–1900. Stem bore 5/64". Unprovenanced find from the Isle of Wight (221007.47).
- Fig. 10.87 Bowl with leaf decorated seams and the maker's initials JD (for James Dyer) relief moulded on the sides of the heel. Dyer operated the pipe works in Orchard Street, Newport from c1885–1900. Stem bore 5/64" (Context 106).
- Fig. 10.88 Bowl with leaf decorated seams and the maker's initials JD (for James Dyer) relief moulded on the sides of the heel. Dyer operated the pipe works in Orchard Street, Newport from c1885–1900. Stem bore 5/64". Unprovenanced find from the Isle of Wight (221007.54).
- Fig. 10.89 Stem fragment with 'thorn' decoration and the incuse moulded lettering L. ANDREWS / NEWPORT I.W. on the sides of the stem. Leonard Andrews operated the pipe works in Orchard Street, Newport from c1903 until at least 1911. Stem bore 5/64". Unprovenanced find from the Isle of Wight (221007.71).

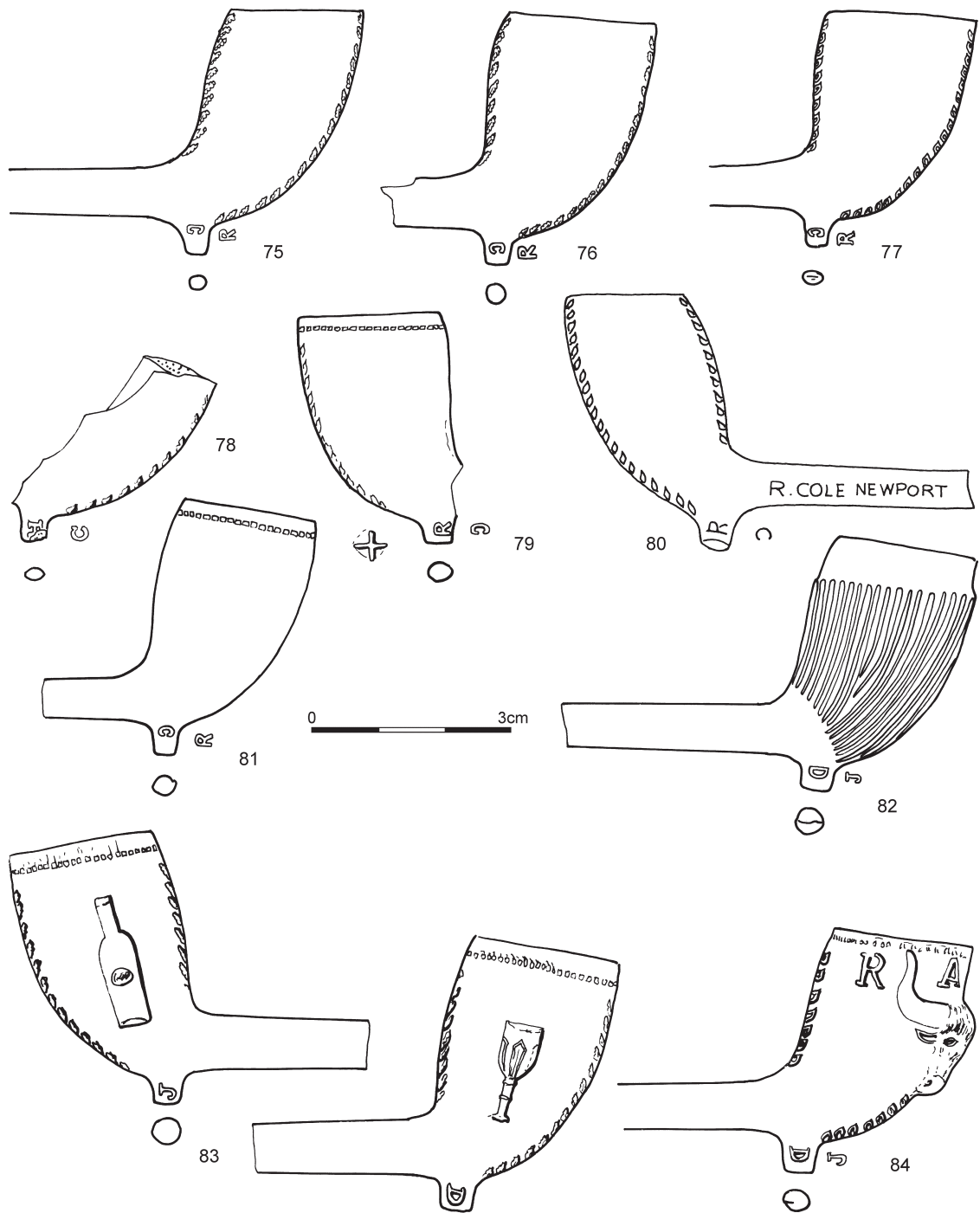

Fig. 9 Late Eighteenth-century and later pipes, Nos 75–84

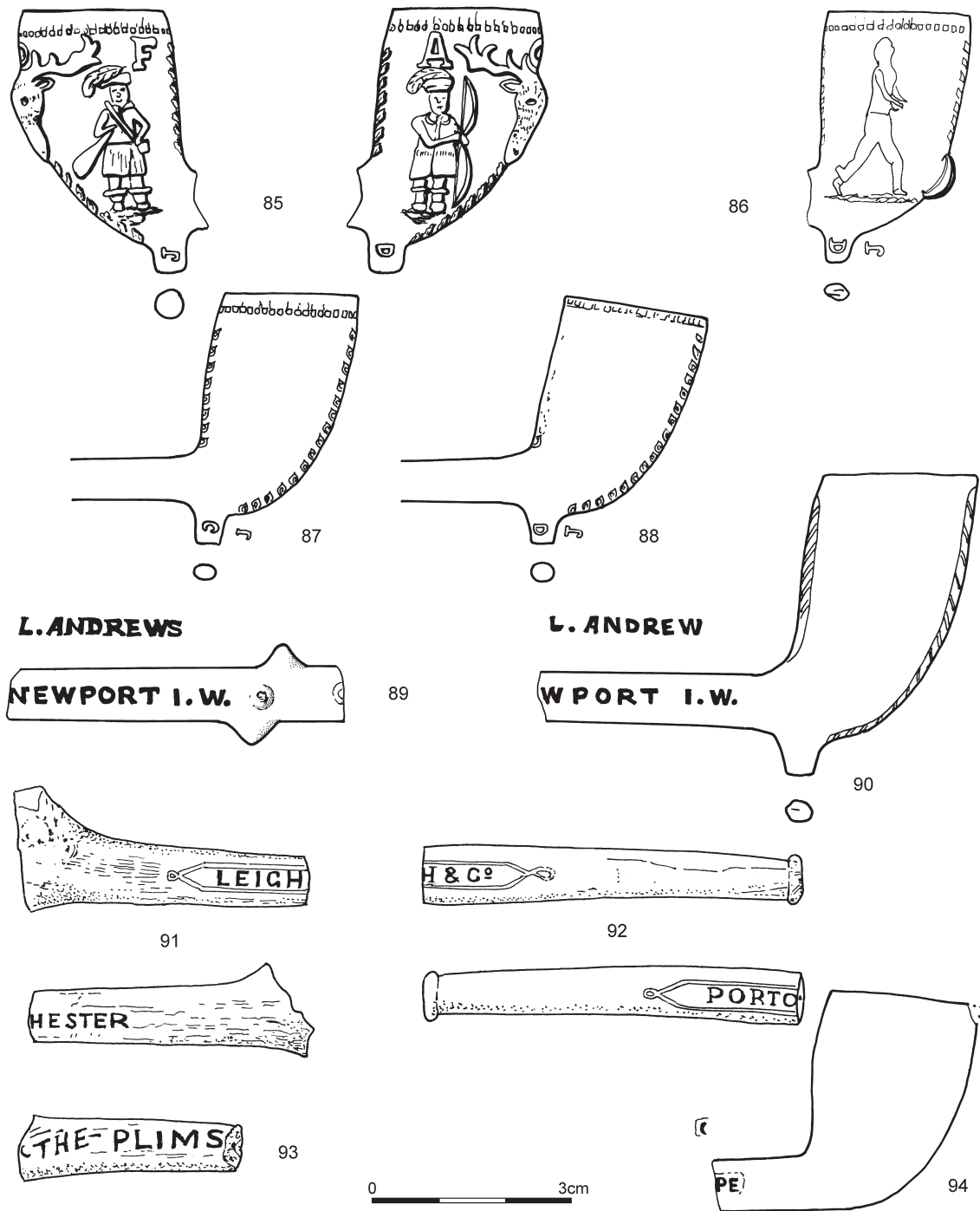

Fig. 10 Late Eighteenth-century and later pipes, Nos 85–94



- Fig. 10.90 Bowl with leaf seams and the incuse moulded lettering L. ANDREW(S) / (NE) WPORT I.W. on the sides of the stem. Leonard Andrews operated the pipe works in Orchard Street, Newport from c1903 until at least 1911. Stem bore just over 5/64". Unprovenanced find from the Isle of Wight (221007.72).
- Fig. 10.91 Stem fragment with part of an incuse moulded mark reading LEIGH.... / [PORTC] HESTER within a relief moulded and beaded border. Traces of the bowl decoration survive, which would have been a claw design with 'hair' rather than scales around the talons (*cf.* Fox & Hall 1979, fig. 90). Henry James Leigh founded his business in 1840, but this mark is more likely to have read LEIGH & Co when complete, which is the name the business operated under from c1883–1932 (Fox & Hall 1979, 18). (Orchard Street Excavations; I.W.C.A.C. PRN. 1543:20:17).
- Fig. 10.92 Stem fragment and nipple mouthpiece with part of an incuse moulded mark reading LEIGH & Co / PORTCHESTER within a relief moulded and beaded border. Leigh & Co operated from c1883–1932 (Fox & Hall 1979, 18; Orchard Street Excavations; I.W.C.A.C. PRN. 1543:20:17).
- Fig. 10.93 Stem fragment of c1850–1910 with part of a relief moulded mark illustrated as reading THE PLIMS... on one side of the stem, although the author's notes suggest that the first word (THE) could simply be part of some oddly formed leaf decoration. The other side of the stem is blank. (Orchard Street Excavations; I.W.C.A.C. PRN. 1543:20:17).
- Fig. 10.94 Plain spurless bowl of c1850–1920 with just the very ends of an incuse moulded mark on the stem; C?... / ...PE. This is most likely to have been a pattern name or slogan, such as CUTTY PIPE, rather than an actual maker's mark. Stem bore 3/64" (Context 302).
- Fig. 11.95 Bowl of c1800–1850 with what appears to be a grapevine or hops and ear of barley design. There is a moulded symbol mark on the heel and traces of stem decoration as well. (Orchard Street Excavations; I.W.C.A.C. PRN. 1543:14:11).
- Fig. 11.96 Bowl of c1840–1880 with glass and bottle decoration. This piece also has the very end of some stem lettering surviving (R... / ...RT), which would almost certainly have read R. COLE / NEWPORT originally. Cole operated the pipe works in Orchard Street, Newport from c1839–1885. (Orchard Street Excavations; I.W.C.A.C. PRN. 1543:1:8).
- Fig. 11.97 Bowl of c1840–1880 with glass and bottle decoration. There is a single surviving dot on each side of the stem, which is probably the start of stem decoration and/or a maker's mark. (Orchard Street Excavations; I.W.C.A.C. PRN. 1543:1:7).
- Fig. 11.98 Fluted bowl of c1800–1900 with heel or spur missing (Orchard Street Excavations; I.W.C.A.C. PRN. 1543:1:4).
- Fig. 11.99 Bowl with acorn and oak leaf design of c1850–1910 (Orchard Street Excavations; I.W.C.A.C. PRN. 1543:1:11).
- Fig. 11.100 Part of a bowl of c1870–1910 modelled in the form of a boot (Orchard Street Excavations; I.W.C.A.C. PRN. 1543:1:16).
- Fig. 12.101 Bowl fragment of c1850–1910 with a flower design (Orchard Street Excavations; I.W.C.A.C. PRN. 1543:7:10).
- Fig. 12.102 Bowl of c1880–1910 with a very slightly different depiction of a cyclist riding a penny farthing bicycle on each side. A number of examples of this pipe are known from the Isle of Wight, including the Orchard Street Excavations (I.W.C.A.C. PRN. 1543:1:14), and it was almost certainly produced at the factory there, with James Dyer, who ran the works from c1885–1899 being most likely maker to have introduced the design. The stem of this pipe is 9cm long and had a flattened oval section before the mouthpiece. Composite drawing from two unprovenanced pieces from the island (221007.102 and 2312.2).
- Fig. 12.103 Spurless bowl with a claw design and the date 1887, presumably made to celebrate Queen Victoria's golden jubilee of that year. This design was possibly made by James Dyer, who operated the pipe works in Orchard Street, Newport from c1885–1899. Stem bore 4/64". (Context 300).
- Fig. 12.104 Spurless bowl with a claw design and the date 1887, presumably made to celebrate Queen Victoria's golden jubilee of that year. This design was most likely made by James Dyer, who operated the pipe works in Orchard Street, Newport from c1885–1899 (this example is very hard fired and may be a waster from the Orchard Street site). Stem bore 4/64". Unprovenanced find from the Isle of Wight (221007.74).

#### *Marked pipes*

A total of 34 fragments with makers' marks or other lettering on them were recovered from

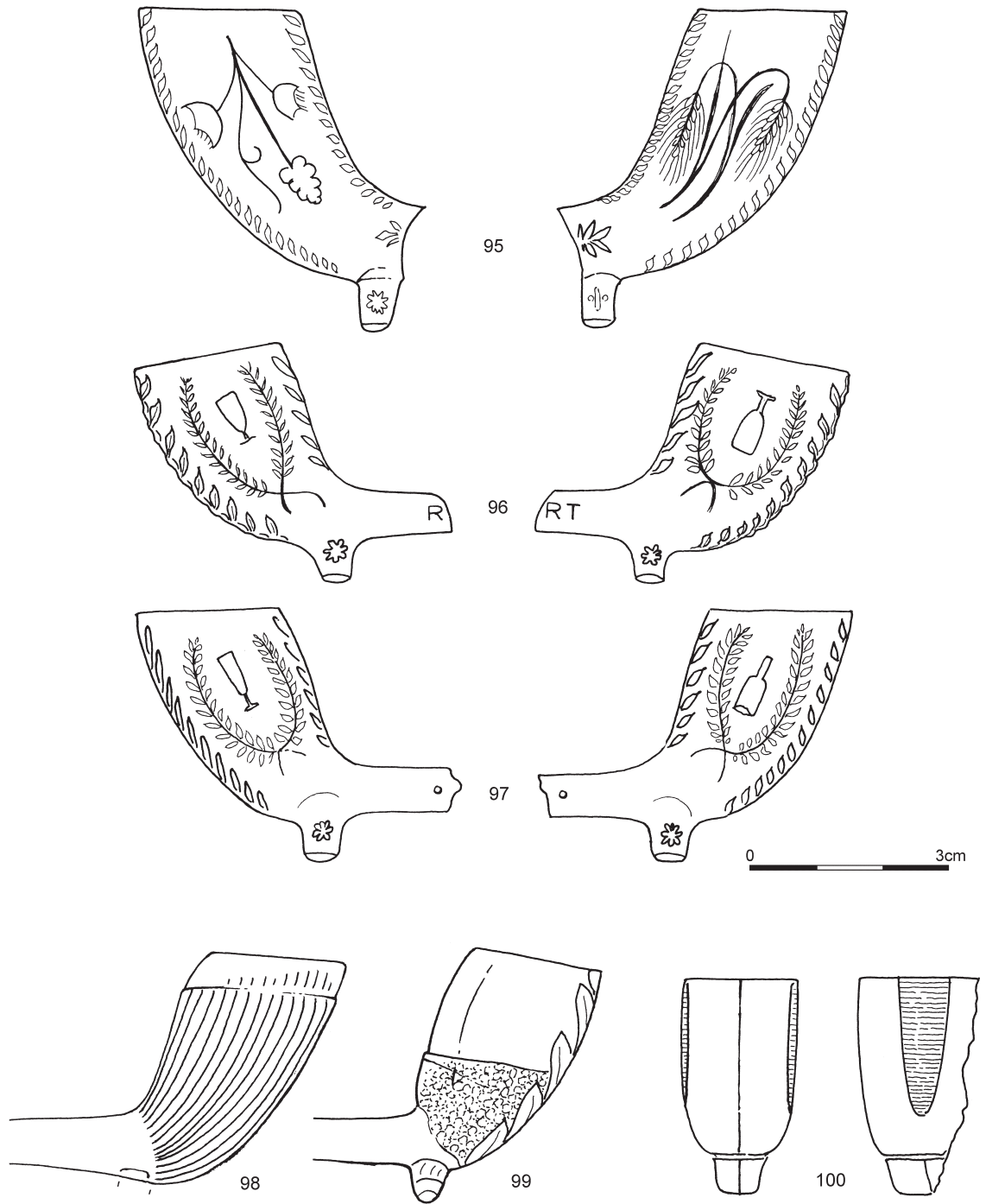

Fig. 11 Late Eighteenth-century and later pipes, Nos 95–100

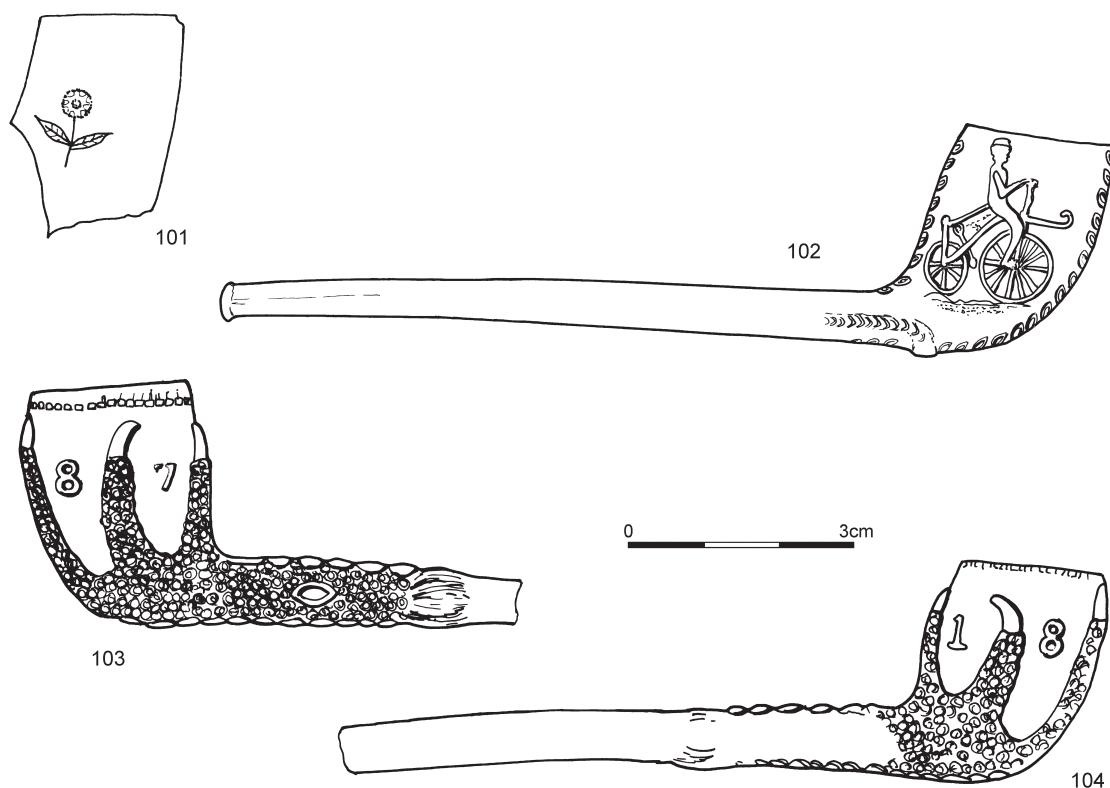

Fig. 12 Late Eighteenth-century and later pipes, Nos 101–104

the recent castle excavations. The earliest group of marks are six incuse stem stamps dating from the first half of the eighteenth century. These reflect the dominance of the Stephens family at this period, with five marks of John Stephens and one of Richard Stephens (e.g., Fig. 5, 44 & 48). The products of these two makers are also represented by a further three spurs with moulded initials (two marked IS and one RS; Fig. 5, 46–47 & 49). Other moulded initial and symbol marks date from this period but cannot be identified, apart from one marked WA, which is probably William Ally (Fig. 3, 23).

There is then a gap until the late eighteenth century when moulded marks reappear. Most of the recently excavated marks belong to makers working at the Orchard Street factory in Newport, whose products clearly dominated supplies to the castle. Some marks from neighbouring parts of the mainland occur as well as

some later nineteenth-century stamped stem marks from Broseley in Shropshire. The latest marks include the initials of organisations (RAOB; AOF), commemorative dated pipes (1897) and fragments that are probably just pattern names, such as 'Burns Cutty'. Details of all the marks recovered from the recent excavations are given in Table 2 below. So far as possible the name marks have been grouped first by maker, followed by date marks, symbol marks and, finally, incomplete/illegible marks.

#### *Traded pipes*

The very earliest pipes would of necessity have been imported to the island but the majority of the pipes found from the middle of the seventeenth century appear to have been made there, as evidenced by local bowl forms and marks. There would always have been occa-

*Table 2* Marked pipes from the 2006 excavations including context number (cxt), a brief note of any decoration, the mark, its type and position (m = moulded; s = stamped) and the suggested date and maker. Open pipe numbers indicate that the actual excavated example is illustrated; bracketed pipe numbers indicate that an identical or very similar example from elsewhere has been illustrated

<i>Cxt</i>	<i>Dec, etc</i>	<i>Mark</i>	<i>Type</i>	<i>Date</i>	<i>Suggested Maker</i>	<i>Suggested Origin</i>	<i>Fig</i>	<i>Comments</i>
224		WA?	M - heel	1690–1730	William Ally?	Newport?	23	A thin-walled transitional heel form of c1690–1730 with a bottered rim and moulded initials that probably read WA (the A being slightly unclear). Possibly William Ally, whom Fox and Barton list as a Newport maker (1986, 188).
100	flutes and leaf seams	RC	M - heel	1839–1885	Robert Cole	Newport	(71)	Bowl fragment with a large heel, fluted decoration and leaf seams (simple open leaves; bowl similar to author's example 221007.29, but from a different mould; Fig 71) and the moulded initials RC on the heel. Made by Robert Cole of Newport (working c1839–1885).
100	Moulded milling	RC	M - heel	1839–1885	Robert Cole	Newport	81	A plain bowl with moulded milling around the rim made by Robert Cole of Newport (working c1839–1885).
224	Leaf seams and moulded milling	RC	M - heel	1839–1885	Robert Cole	Newport	79	An almost complete bowl with moulded milling, leaf seams and initials RC on the spur (Robert Cole, Newport, c1839–1885). This bowl has an internal bowl cross, made of quite fine lines and arranged as an upright '+' in relation to the long axis of the pipe.
301	-	RC	M - heel	1839–1885	Robert Cole	Newport		Only a large chunky spur marked RC survives.
301	Leaf seams	RC	M - heel	1839–1885	Robert Cole	Newport	(73)	Part of the bowl marked RC with leaf decorated seams (from the same mould as an example in the author's possession; 221007.30; Fig 73).
306		RC	M - heel	1839–1885	Robert Cole	Newport	(81)	The moulded initials RC on the heel of a pipe with a very thin stem and what appears to have been a plain bowl (very little survives, and no rim). Almost certainly made in the same mould as Fig 81 by Robert Cole of Newport, working c1839–85.
308 - 310		RC	M - heel	1839–1885	Robert Cole	Newport	(81)	Plain bowl (damaged) with a thin stem and the moulded heel mark RC. Almost certainly made in the same mould as Fig 81 by Robert Cole of Newport, working c1839–85.
124		R -	M - heel	1839–1885	Robert Cole	Newport	72	Part of a nineteenth century bowl with fluted decoration and Christian name initial R, arranged upright on a shield-shaped background on the side of the heel or spur. The surname side is chipped, but the most likely maker would be Robert Cole of Newport, working c1839–85.

Table 2 (cont.)

<i>Cxt</i>	<i>Dec, etc</i>	<i>Mark</i>	<i>Type</i>	<i>Date</i>	<i>Suggested Maker</i>	<i>Suggested Origin</i>	<i>Fig</i>	<i>Comments</i>
300	Flowers / foliage; leaf seams etc	R. COLE / NEWPORT	M - bowl	1839-1885	Robert Cole	Newport	(64)	Fragment from a bowl with an elaborate design that would have had banner reading R. COLE / NEWPORT under the decoration on each side of the bowl. Two forms of this design are known, this example being from the type where the banner turns up sharply towards the front of the bowl (see Fig 64, which is a complete example from Orchard Street).
106	Leaf seams and moulded milling	JD	M - heel	1885-1900	James Dyer	Newport	87	A complete bowl with moulded milling, leaf seams and initials JD on the spur (James Dyer, Newport, c1885-1900), made in the same mould as an example in the author's possession (221007.54). The excavated example, however, has a much less worn rim, showing both that this is an earlier example and that the mould was in use for some time to have become so worn.
301	Leaf seams	JD	M - heel	1885-1900	James Dyer	Newport		A small heel marked JD with traces of leaf decorated seams. This was made by James Dyer, c1885-1900, but not enough survives to match the specific mould.
301	Buffalo head and leaf	(JD) / RAOB	M - bowl	1885-1900	James Dyer	Newport	(84)	Part of an RAOB bowl from the same mould as a complete example in the author's possession (221007.40; Fig 84), which shows that it would originally have been marked JD on the heel. This was made by James Dyer of Newport, c1885-1900.
308 - 310	leaf seams	I? F	M - spur	1800-1880	Frost	Portchester or Southampton	55	Spur fragment with just a small amount of surviving bowl (leaf seams visible) and the moulded initials that probably read IF, although they are slightly unclear and FF, LF or TF are other possibilities. If the initials IF are correct, the most likely maker is James Frost of Portchester (born 1743, died 1827; Fox & Hall 1979, 28). If they are TF then the maker could be Thomas Frost of Southampton, recorded from at least 1804-43 (Oswald 1975, 172).
140		WG?	M - spur	1690-1750			51	Two joining fragments from an early eighteenth century style spur bowl with moulded initials WG? (the surname unclear). No known makers with the initials WG in Hampshire or on the Isle of Wight.
308	Leaf seams	CR	M - heel	1840-1900	Robert Cole	Newport	78	Bowl fragment with leaf seams marked CR, perhaps in error for RC (Robert Cole, working c1839-1885). There are no other known makers with these initials from Hampshire or the Isle of Wight.

Table 2 (cont.)

<i>Cxt</i>	<i>Dec, etc</i>	<i>Mark</i>	<i>Type</i>	<i>Date</i>	<i>Suggested Maker</i>	<i>Suggested Origin</i>	<i>Fig</i>	<i>Comments</i>
124		IS × 2	M – spur	1700–1750	John Stephens	Newport	46, 47	Two early eighteenth century spur bowls with moulded IS marks for one of the Newport makers of this name working c1700–50 (made in different moulds).
106		IOHN / STEP / HENS	S – stem	1700–1750	John Stephens	Newport	(45)	An eighteenth century stem stamp reading IOHN STEPHENS for one of the two Newport makers of this name, working c1700–1750. The mark is of a similar form to that shown in Fig 45, but impressed using a different die.
124		IOHN / STEP / HENS	S – stem	1700–1750	John Stephens	Newport	44	An eighteenth century stem stamp reading IOHN STEPHENS for one of the two Newport makers of this name, working c1700–1750. This particular die is distinctive in that the ‘N’ of ‘IOHN’ is retrograde and the T and E of ‘STEPHENS’ are ligatured together. A more complete impression of this die type is illustrated by Walker from a 1740s context at Louisbourg (1967, Fig 3), which shows that in the last line the H and the E would also have been ligatured together and that the N would have been retrograde too.
208		IOHN / STEP / HENS	S – stem	1700–1750	John Stephens	Newport	(45)	An eighteenth century stem stamp reading IOHN STEPHENS for one of the two Newport makers of this name, working c1700–1750. The mark is of a similar form to that shown in Fig 45, but impressed using a different die.
301		IOHN / STEP / HENS	S – stem	1700–1750	John Stephens	Newport	(45)	An eighteenth century stem stamp reading IOHN STEPHENS for one of the two Newport makers of this name, working c1700–1750. The top of the die is poorly impressed, but it would have been of the same form as the mark shown in Fig 45.
103		IOHN / ...	S – stem	1700–1750	John Stephens	Newport	(45)	Part of an eighteenth century stem stamp starting IOHN..., almost certainly part of a IOHN STEPHENS mark from Newport, as illustrated in Fig 45 (there were two Newport makers of this name, working c1700–1750).
205		RS	M – spur	1690–1740	Richard Stephens	Newport	49	An early eighteenth century spur bowl in a local style with the moulded initials RS. Made by Richard Stephens of Newport, who took apprentices in 1719 and 1720.

Table 2 (cont.)

<i>Cxt</i>	<i>Dec, etc</i>	<i>Mark</i>	<i>Type</i>	<i>Date</i>	<i>Suggested Maker</i>	<i>Suggested Origin</i>	<i>Fig</i>	<i>Comments</i>
224	RICH / STEP / HENS	S - stem	1700-1740	Richard Stephens	Newport	48	An early eighteenth century stem stamped RICH / STEP / HENS for Richard Stephens of Newport, who took apprentices in 1719 and 1720.	
224	W.SOUTHORN & Co / BROSELEY ... x 2	S - stem	1850-1960	William Southorn & Co	Broseley		Two stems with incuse stem stamps along them from the well known firm of W. Southorn & Co from Broseley, Shropshire. One is on a thin stem and the mark is complete but poorly impressed so the worker's number at the end cannot be read, while the other is incomplete and on a medium thickness stem, which has been burnt.	
301	W.SOUTHORN & Co / BROSELEY ...	S - stem	1850-1960	William Southorn & Co	Broseley		A thin stem with part of an incuse stem stamp along it from the well known firm of W. Southorn & Co from Broseley, Shropshire.	
300	Claw design	M - bowl	1887-1900	James Dyer	Newport	103	Complete claw bowl with the date 1887 moulded as part of the design and decoration extending along about half of the stem. Other examples known from the island (for example, one in the author's possession from the same mould; 221007.76) and so probably made there, most likely by James Dyer in Newport.	
308 - 310	sun or flower with dot	M - heel	1700-1760			24	An eighteenth century bowl fragment with a sun or flower symbol mark with a central dot moulded on each side of the heel. A range of broadly similar symbol marks were being produced at the Oyster St kiln in Portsmouth c1700-40 (Fox and Hall 1979, Figs 3.13-3.16).	
301	banner	M - heel	1839-1885	Robert Cole	Newport		A spur with a ring and dot motif and part of a banner visible on the surviving bowl, which may be part of an R Cole design (but a different mould from Figs 63-64).	
308 - 310	?? x 2	M - spur	1690-1740	-	-		Two fragments with damaged moulded marks and the bowls completely missing. They were both probably spur types, but even this is not certain. One of them might possibly have read IS for John Stephens of Newport (c1700-1750).	
302	Plain bowl	M - stem	1850-1920			94	Plain spurless cutty bowl with part of an incuse moulded sans-serif stem mark, probably with a pattern name such as CUTTY PIPE rather than an actual maker's mark.	

sional seventeenth-century imports from the near mainland, such as the Gauntlet mark from earlier excavations at the castle (Brereton 2000, fig. 64.27) but these do not appear in quantity or for any particular maker. There are also a few overseas imports of seventeenth-century Dutch pipes, which were illustrated but not recognised by Brereton (2000, figs 64.19, 20 and 23). Dutch pipes were always rare on inland sites in England but do occur in small numbers at coastal ports.

Exports of pipes from the island are documented from at least 1666 and, during the first half of the eighteenth century, John Stephens was exporting pipes to the mainland as well as the Channel Islands and Nova Scotia (see above). Early eighteenth century pipes made by Richard Stephens and William Ally have also been recorded from Guernsey (David 2003), suggesting that a strong cross Channel trade has already been established by this date. There is no evidence for the later eighteenth century but, by the nineteenth century, Robert Cole had clearly built up a considerable business and was sending large numbers of pipes along the coast, particularly to Torbay (Coleman 2013). There was also a good trade of pipes to France, which continued into the twentieth century (Carisbrooke Castle Museum files: D.1986.2896.105) – and which may have started well before this given the numbers of earlier pipes that have been recorded from the Channel Islands. By the same token, pipes from neighbouring parts of the mainland found their way to the island, particularly those from makers in the Portsmouth Harbour area. The late nineteenth century and early twentieth-century pipes made by Leigh & Co of Portchester are particularly numerous.

No evidence has been found of British coastal trade from further afield arriving on the island, despite Liverpool pipes having been seen by the author from the nearby Poole Harbour area. There are, however, a few Broseley pipes from Shropshire amongst the castle finds showing that special types of pipe (in this case good quality churchwardens) could find a niche market amongst the predominantly local types that were being used. The same applies to the few foreign nineteenth-century pipes that have been recorded for the island; some

Dumeril pipes from a Newport bottle dump and a French stem made in St Omer from the castle itself (Brereton 2000, 170 & fig. 64.16).

Overall it seems clear that the island was able to be self sufficient in pipes from at least the mid seventeenth century onwards and that there was no systematic influx of traded pipes. Those types that do occur are only present in small numbers and mostly reflect the general circulation of pipes that would be expected within the region and from passing shipping. If anything, it is the exported pipes that seem to be more notable, with significant numbers of pipes from the island reaching the Channel Islands and Nova Scotia during the eighteenth century, large numbers of Robert Cole's pipes reaching the Torbay area during the nineteenth century and a documented trade with France that lasted into the twentieth century.

## SUMMARY AND CONCLUSIONS

Although the pipes from the 2006 and 2008 excavations at Carisbrooke castle are generally rather fragmentary and primarily from mixed contexts, they still provide a good sample of the pipes that were being used at the site from the mid seventeenth century onwards. When placed within their broader context they allow an examination of the island's pipemaking history as well as shedding light on the range and nature of the pipes that were being used at the castle itself. This study has brought together a number of key groups to provide a corpus of forms, decoration and marks for the island, as well as the first dedicated list of pipemakers for the Isle of Wight. The study has revealed an industry that was able to use local clays from an early period and that was vibrant enough to develop its own distinctive styles by the middle of the seventeenth century. The island's pipemakers were aware of changing fashions and their products reflect regional trends of the day. The pipes they made were of a sufficient quality and range as to ward off imports and, if anything, the island seems to have exported more pipes than it received. The industry flourished throughout the nineteenth century and continued until 1938, when pipemaking had already ceased in many other parts of the



country. The pipes used at the castle itself were predominantly sourced from local manufacturers in Newport but included some good quality products, as is shown by the presence of a few burnished seventeenth-century fragments, a small number of imported Dutch pipes and some good quality straws and churchwardens in the nineteenth century.

#### ACKNOWLEDGEMENTS

Many people have helped make this study possible and thanks are due to all those who have helped along the way. The late Sarah Jennings at English Heritage was keen to see the excavated pipes set within a wider survey of material from the island while Rebecca

Loader (HER/Archaeological Projects Officer) and Corina Westwood at the museum service both provided invaluable assistance by making excavated material and archive collections available for study and by allowing previously unpublished drawings from the HER to be used in this report. Thanks are also due to Martin Munt at the museum service for his notes on the geology of the island's pipe clay deposits and to Chris Yendall at Carisbrooke Castle Museum and Marek Lewcun from Norton St Philip for additional references that have been added to the list of pipemakers. Finally, particular thanks are due to Dr Susie White who not only helped compile the new list of pipemakers for the island but also drew most of the pipes and laid out all the figures for publication.

#### REFERENCES

- Arnold, C J 1977 The clay tobacco-pipe industry: an economic study, in Peacock, D P S (ed.) *Pottery and Early Commerce*, London, 313–336.
- Atkinson, D R 1975 The clay tobacco pipes, in Platt, C & Coleman-Smith, R *Excavations in Medieval Southampton 1953–69*, Vol. 2, Leicester, 344–349.
- Brereton, S 2000 Clay tobacco pipes, in Young, C J *Excavations at Carisbrooke Castle, Isle of Wight, 1921–1996*, Wessex Archaeology Report 18, Trowbridge, 167–173.
- Coleman, H 2013 Robert Cole: a few notes on the pipe maker of Newport, Isle of Wight, *Society for Clay Pipe Research Newsletter* 83 20–24.
- Cooksey, A J A 1980 The clay tobacco pipe in the Poole area, in Davey, P (ed.), *The Archaeology of the Clay Tobacco Pipe*, III (BAR Int Ser 78), Oxford, 337–347.
- David, N 2003 Clay tobacco pipes, in Barton, K J *The Archaeology of Castle Cornet, St Peter Port, Guernsey*, Guernsey Museum Monograph 7, 231–278.
- Fox, R T & Hall, R B 1979 *The Clay Tobacco Pipes of the Portsmouth Harbour Region 1680–1932*, privately published.
- Fox, R & Barton, K J 1986 The clay pipes, in Excavations at Oyster Street, Portsmouth, Hampshire, 1968–71, *Post-Medieval Archaeol* 20 185–223.
- Fuller, T 1662 *The History of the Worthies of England*, London.
- Higgins, D A 1987 *The Interpretation and Regional Study of Clay Tobacco Pipes: a case study of the Broseley District*, unpubl PhD thesis, University of Liverpool.
- Higgins, D A 2011 Clay tobacco pipes, in Brown, R & Hardy, A *Trade and Prosperity, War and Poverty: an archaeological and historical investigation into Southampton's French Quarter*, Oxford Archaeology Monograph, 15, Oxford, 199–207, specialist download F2: [http://library.thehumanjourney.net/48/1/SOU\\_1382\\_Specialist\\_report\\_download\\_F2.pdf](http://library.thehumanjourney.net/48/1/SOU_1382_Specialist_report_download_F2.pdf).
- Markell, D J 1983 The clay tobacco pipes, in Davies, S M *Excavations at Christchurch, Dorset 1981–3*, *Proc Dorset Natur Hist Archaeol Soc* 105 21–56.
- Markell, D J 1992 The clay tobacco pipes, in Horsey, I P & Anderson, F W *Excavations in Poole 1973–1983*, Dorset Natural History and Archaeological Society Monograph Series, 10, 159–75.
- Oswald, A 1975 *Clay Pipes for the Archaeologist* (BAR Brit Ser 14), Oxford.
- Oswald, A 1991 *Pipe Stamp Index* (4 Vols), unpublished material, National Pipe Archive, University of Liverpool (LIVNP 1997.8).
- Price, R 2013 *Bristol Pipemakers, and Their Families*,

- of the 16<sup>th</sup> to 20<sup>th</sup> Centuries, unpublished material, National Pipe Archive, University of Liverpool.
- Russell, M 2017 Excavations in and around the privy garden, Carisbrooke Castle, Isle of Wight, 2006 and 2008–9, *Proc Hampshire Fld Club Archaeol Soc* **72** 61–128.
- Trott, K 2001 The excavation of a Post-Medieval midden located during a watching brief at Riverway Industrial Estate Newport, Isle of Wight, *Proc Isle Wight Natur Hist Archaeol Soc* **17** 41–54.
- Venables, E 1860, *A Guide to the Isle of Wight*, London.
- Walker, I C 1967 Clay pipes from the Fortress of Louisbourg, *Archaeology* **20.3** 187–193.
- Walker, I C 1977 Clay tobacco pipes, with particular reference to the Bristol industry, *History and Archaeology*, Vols **11a–11d**, Ottawa.
- Websites*
- British Newspaper Archive: <http://www.britishnewspaperarchive>
- FreeBMD: <http://freebmb.org.uk>
- Historical Directories online: <http://www.historical-directories.org/hd/>
- Knightroots: [http://www.knightroots.co.uk/transcriptions/Parishes\\_F/Fareham/Marriages\\_marriages.htm](http://www.knightroots.co.uk/transcriptions/Parishes_F/Fareham/Marriages_marriages.htm) [accessed 6 Jun 2013]
- MBD – Men Brewery Deeds held by the Isle of Wight Record Office (ELD for 1578–1912): <http://www.nationalarchives.gov.uk/a2a/records.aspx?cat=189-eld1&cid=3-23#3-23> [accessed 11 Jun 2013]
- NBAI – Newport Borough: Apprenticeship Indentures (NBC/3 for 1689–1835): <http://www.nationalarchives.gov.uk/a2a/records.aspx?cat=189-nbc3&cid=-1#-1> [accessed 6 Jun 2013]
- NBCD – Newport Borough Corporation Charters and Deeds (NBC/1 for c11180–1954): [http://www.nationalarchives.gov.uk/a2a/records.aspx?cat=189-nbc1\\_1&cid=-1#-1](http://www.nationalarchives.gov.uk/a2a/records.aspx?cat=189-nbc1_1&cid=-1#-1) [accessed 6 Jun 2013]

*Author.* Dr David Higgins, 3 Clarendon Road, Wallasey, Merseyside, CH44 8EH.  
Email: [D.A.Higgins@liverpool.ac.uk](mailto:D.A.Higgins@liverpool.ac.uk)

© Hampshire Field Club and Archaeological Society

## APPENDIX: ISLE OF WIGHT PIPEMAKERS

There has never been a dedicated list of pipemakers known to have worked on the Isle of Wight, the only previous list being mixed within the Hampshire pipemakers published by Oswald in 1975. The list compiled by Oswald only provided brief references to each maker and no details of family relationships or the address at which they worked. The 1975 references are not only mixed amongst all the other Hampshire pipemakers, making them hard to pick out, but the details are now also rather out of date.

The following list has taken the names collected by Oswald as its starting point and then added additional information and entries from some of the more obvious online sources, such as census records, the Mormon Church's International Genealogical Index (IGI), digitised trade directories, etc. Details of the sources searched are given with the other references. It has not been possible to examine all the all the online resources or any original archives for this study, but it has still been possible to nearly double the number of known makers from 22 to around 40, as well as adding a lot more detail to the lives of those that were already known.

The list is arranged in alphabetical order by initials (surname first, then Christian name; and then in date order for matching initials) to facilitate the identification of pipe marks (which often just comprise initials). The letter J has been given as I, which is also the usual form found on marks. The place(s) that each maker worked are given in brackets after his or her name. For each entry two date ranges are given; first the date(s) when that individual is actually recorded as a pipemaker and, second, the date(s) when they are likely to have been pipemaking, based on what is known about them. This information is then followed by specific details of their lives, when known, including birth date, marriage, details about their children, etc. In the case of the nineteenth-century makers information extracted from the census records is given in date order.

Passing references to individuals who are known to have worked in the pipe trade are indicated by their name being underlined, but only those who have actually worked on the Isle of Wight have their own entry.

Unless otherwise stated, all census information was extracted from the Genes Reunited website (accessed June 2013) and all birth, marriage

or death dates are from the FreeBMD website (accessed June 2013).

*Abbreviations used*

- b. – Born
- bap. Baptised
- Q1 – First Quarter (January-March), followed by the year
- Q2 – Second Quarter (April-June), followed by the year
- Q3 – Third Quarter (July-September), followed by the year
- Q4 – Fourth Quarter (October-December), followed by the year

**IA – ALLY, John** (*Newport*)

**Recorded as a pipemaker:** 1730–1747

**Likely to have been pipemaking:** +1730–1747+

**Born:** Possibly the John, son of William Ally, baptised at Newchurch on 18 November 1692

**Married:** Anne

This eighteenth-century maker is known from pipe stems marked IOHN / ALLY with his name above a pair of crossed pipes. He appears in the Newport Apprenticeship Indentures listed as a pipemaker a number of times between 1730 and 1747 as follows (in the apprenticeship records the surname is spelt Alley):-

1730 Took Mary Atwood of Newport apprentice 2 Jun 1730, together with Anne his wife (NBAI Ref. NBC/3/148).

1733 Took Anne Jacob of Newport apprentice to learn the work of a housewife 7 Sep 1733, together with Anne his wife (NBAI Ref. NBC/3/168).

1744 Took Elizabeth Foquet of Newport apprentice to learn the work of a housewife 6 Apr 1744 (NBAI Ref. NBC/3/222).

1746 Took Francis Cormick of Newport apprentice 4 Jul 1746 (NBAI Ref. NBC/3/225).

1747 Took Henry Young of Newport apprentice 2 Sep 1747 (NBAI Ref. NBC/3/233).

No other records that list John Ally as a pipemaker have been found, but he may well have been related to the pipemaker William Ally. Fox & Barton (1986, 188) give an unsourced reference to William Ally being a Newport pipemaker and a William Ally is recorded working at Winchester from c1730–77 (Oswald 1975, 171), perhaps the same maker or a son of

the same name who moved there. An individual named William Alley (occupation unknown) had a son John baptised at Newchurch on 18 November 1692 (Ancestry, accessed 19–6–13), who may well have been the pipemaker John Ally recorded at Newport during the first half of the eighteenth century. If so, then it seems likely that both father and son were pipemakers. Four stamped stems made by John Ally (two with their bowl forms still attached) as well as three Armorial bowls with Hanoverian Arms and the moulded spur initials IA have been found associated with possible kiln waste produced by John Stephens at the Riverway Industrial Estate in Newport (Trott 2001, 49–50).

**LA – ANDREWS, Leonard** (*Newport*)

**Recorded as a pipemaker:** 1904–1911

**Likely to have been pipemaking:** c1903–1911+

**Born:** 1873 Q2 in Winchester (FreeBMD)

**Married:** Minnie (b. c1879, Newport)

**Children:** Edith Kate (b. c1901, Cambridge), Harold Leonard (b. c1903, Cambridge), Gladys (b. c1904, Newport), Dorothy Minnie (b. c 1905, Newport), Clara Marjory (b. c1908, Newport), Ernest (b. c1909, Newport) and Reginald (b. 1911, Newport)

**Died:** Q1 1958 Isle of Wight aged 84 (FreeBMD)

*Census Information*

**1881** – Aged 8 listed as a scholar living at 36 Southgate Street, Winchester with his parents Alfred (coachbuilder, 49) and Jessie (43) and siblings Alfred (coachbuilder, 18), James L (2) and Jessie M (1 month).

**1891** – Aged 18 listed as a bank clerk lodging at 13 Elm Grove, Carisbrooke together with his brother Walter (chemist's assistant, 29).

**1901** – Aged 28 listed as an estate agent's cashier and accountant, living at 27 Humberstone Road, Chesterton, Cambridgeshire, with his wife Minnie (22).

**1911** – Aged 38 listed as a manufacturer of fire-clay and pipe-clay, living at 18 Orchard Street, Carisbrooke (Newport) with his wife Minnie (32) and children Edith Kate (10), Harold Leonard (8), Gladys (7), Dorothy Minnie (6), Clara Marjory (3), Ernest (2) and Reginald (3 months).

Leonard was born in the second quarter of 1873 in Winchester, the son of Alfred and Jessie Andrews (FreeBMD). Leonard appears in the 1891 census as a bank clerk in Carisbrooke and in 1901 as an estate agent's cashier and account-

ant in Cambridge. He married Minnie c1900 and they had at least seven children, the first two of which were born in Cambridge (in c1901 and c1903). Their later children (c1904 and later) were all born in Newport, showing that he had returned to the island with his family by this date, a fact confirmed by his appearance as a 'pipe manufacturer' at 18 Orchard Street, Newport, in Kelly's 1904 Directory. In the 1911 census he is listed as a manufacturer of fire-clay and pipe clay, but in Kelly's Trade Directory for that year he appears as a 'tobacco pipe manufacturer' living in Newport with his wife and family (Historical Directories online). James Dyer had operated the pipeworks at 18 Orchard Street until his death in the third quarter of 1899. James' widow has not been traced in the 1901 census but the business clearly then passed to Leonard Andrews, who was listed at 18 Orchard Street from at least 1904–1911. Andrews must have moved back to the island in 1903 or 1904 and presumably took over the running of the pipe works from this date. It is not known how long the business continued after 1911. One of the designs produced by Andrews was modelled as a guardsman's head, an example of which dating from 1912 was deposited in the Carisbrooke Castle Museum in 1939 by H. F. Poole (D.1986.2896.106, "a clay with guardsman's head bought in Newport in 1912 and attributed to 'Andrews'.")

**WA – ALLY, William** (*I; ?Newport*)

**Recorded as a pipemaker:** From pipe marks

**Likely to have been pipemaking:** c1690–1730

**Born:** ?1662

**Children:** Possibly John, baptised at Newchurch on 18 November 1692.

Pipes of c1690–1730 marked WA have been found at Carisbrooke Castle and early eighteenth century stem stamps reading WILL / IAM / ALLY are known (Fox & Barton 1986, Fig. 121.98). Despite this, it has not been possible to locate any document that actually lists a pipemaker named William Ally on the island during this period. Fox and Barton (1986, 188) give an unsourced reference to William Ally being a Newport pipemaker and a William Ally is recorded working at Winchester from c1730–77 (Oswald 1975, 171), perhaps the same maker or a son of the same name who moved there. An individual named William Ally, son of Samuel and Katherine, was baptised at Kingston on the Isle of Wight on 18 February 1662. Likewise, a William

Ally (occupation unknown) had a son John baptised at Newchurch on 18 November 1692 (Ancestry, accessed 19–6–13), who may well have gone on to be the pipemaker John Ally recorded at Newport during the first half of the eighteenth century. If these references are all to the same family, then William (I) would have been born on the island and would have been working at the right period for the marked pipes. He would also have been the father of a known pipemaker, and trades often followed in families at this period. There could also be a family connection with the later Winchester pipemaker of the same name, recorded from c1730–77 (Oswald 1975, 171), and with the later William Alley, recorded at Newport in 1773 (see below).

**WA – ALLEY, William** (*II; Newport*)

**Recorded as a pipemaker:** 1773

**Likely to have been pipemaking:** +1773+

The *Hampshire Chronicle* for 15 February 1773 includes the following advertisement: “Newport, Isle of Wight, Feb. 11, 1773. Wanted immediately, a journeyman pipe maker, who understands his business perfectly well, in every part thereof. Such a one may meet with constant employment, on good wages, by applying to Mr. William Alley, pipe-maker, in Newport aforesaid.” This makes it clear that a William Alley was pipemaking in Newport at this date, which is too late for it to be the same person who made the early eighteenth century marked pipes (see above). The wedding of a William Ally and Betty Ballard is recorded at Carisbrooke in 1755 (Boyd’s Marriage Index; no occupation given), perhaps the same person (although the name was quite common in the area).

**GB – BURT, George** (*Carisbrooke*)

**Recorded as a pipemaker:** 1851

**Likely to have been pipemaking:** c1845–1855

**Born:** Bap. 8 Dec 1805 Newport, son of William and Sarah Burt (FreeBMD)

**Married:** 1. Ann Pitt (b. c1808) on 25 Feb 1838 at Whippingham, Hampshire (Ancestry); 2. Mary Adams (b. c1809, Newport) on 25 Feb 1851 at St John, Carisbrooke (IGI)

**Children:** Emily (b. c1838 Carisbrooke); George (b. c1846 Carisbrooke); Henry (b. c1848 Carisbrooke); William (b. c1851 Newport) (Genes Reunited)

**Died:** 1873 (Q1) Isle of Wight aged 67 (FreeBMD)

#### *Census Information*

**1841** – Aged 35 listed as a tailor living in Bowling Green/Orchard Street, Carisbrooke (Newport) with wife Ann (33).

**1851** – Aged 45 listed as a pipe maker living in Bowling Green, Carisbrooke with his wife Mary (42) and three children, Emily (13), George (5) and Henry (3) and his father William (79).

**1861** – Aged 55 listed as a tailor living in 16 Orchard Street, Carisbrooke (Newport) with his wife Mary (51), son George (baker, 16), Son Henry (painter, 13) and son William (scholar, 10).

**1871** – Aged 65 listed as a messenger living in 27 Orchard Street, Carisbrooke (Newport) with his wife Mary (61).

George was born in 1805 in Newport, the son of William and Sarah Burt. He married twice; first to Ann Pit in 1838, with whom he had three children, Emily, George and Henry; second to Mary Adams in 1851 with whom he had a son, William. George appears in the census returns as a tailor in 1841 and 1861, and as a messenger in 1871. He is only listed as a pipemaker in 1851, when he may have been working for one of the more established manufacturers, such as Robert Cole, rather than being a master pipemaker in his own right. He died in the first quarter of 1873, aged 67.

**GB – BUSHELL, George Matthew** (*Ryde*)

**Recorded as a pipemaker:** 1861

**Likely to have been pipemaking:** +1861+

**Born:** c1849, Haylands, Isle of Wight

**Married:** Annie Norris (b. c1852) Q3 1870 Isle of Wight (FreeBMD)

**Children:** George Charles (b. c1872, Ryde), Emma (b. c1875, Ryde), Charles Henry (b. c1878, Ryde) and Albert, (b. 1880, Ryde), Arthur (b. c1882, Ryde), Kate (b. c1885, Ryde), Leonard (b. c1888, Ryde)

**Died:** Q3 1939, Isle of Wight, aged 90 (FreeBMD)

#### *Census Information*

**1851** – Aged 2 living with his parents and grandparents in Newchurch, Ryde.

**1861** – Aged 12 listed as a pipe maker (tobacco) living at Haylands, Newchurch, Ryde, with his parents George (jobbing gardener, 35) and Emma (35) and siblings Henry (scholar, 10) and Arthur (scholar, 6).

**1871** – Aged 22 listed as a labourer living in Wray Street, Ryde with his wife Annie (19).

**1881** – Aged 31 listed as a bricklayer living in Albert Street, Ryde, with his wife Annie (28) and

children George (scholar, 9), Emma (scholar, 6), Charles (scholar, 3) and Albert, (1).

**1891** – Aged 40 listed as a bricklayer living in Alfred Street, Ryde, with his wife Annie (38) and children George (bricklayer 20), Charles (porter, 13), Albert (scholar 12), Arthur (scholar, 9), Kate (scholar, 6), Leonard (3).

**1901** – Aged 52 listed as a bricklayer living in Alfred Street, Ryde with his wife Annie (49) and children George (brick maker, 29), Charles (brick maker, 23), Arthur (brick labourer, 19) and Leonard (13).

**1911** – Aged 62 listed as a brick maker living in Glendale Lower Bettsworth Road, Ryde, with his wife Annie (51) and children George Charles (general labourer, 39), Charles Henry (general labourer, 33), Arthur (general labourer, 29), Kate (dressmaker, 26) and Leonard (general labourer, 23).

George was born c1849, son of George and Sarah Bushell, in Ryde, Isle of Wight. He is only listed as a tobacco pipe maker when he was 12 and goes on to spend the rest of his working life as a brickmaker. The fact that he was living at home but working as a pipemaker in Ryde at such a young age suggests that there may have been a pipeworks somewhere in the town at this date.

#### **HB – BURT, Henry** (*Newport*)

**Recorded as a pipemaker:** 1719

**Likely to have been pipemaking:** +1719+

1719 – Richard Stephens of Newport, tobacco pipemaker, took Henry Burt apprentice on 31 Mar 1719 (NBAI Ref. NBC/3/101)

#### **IB – BRAY, John** (*Newport and Fareham*) – **See also STEPHENS, John II**

**Recorded as a pipemaker:** 1719 (Newport); 1745–1766 (Fareham)

**Likely to have been pipemaking:** 1719–1766

**Married:** Jane Street at Portsmouth in 1745 (d. 1750); re-married 1751 (Fox & Hall 1979, 20)

**Died:** 1766 (Fox & Hall 1979, 20)

1719 – Elizabeth Stephens of Gosport took John Bray alias Stephens of Newport apprentice on 3 Aug 1719, to learn the trade of tobacco pipe-making (NBAI Ref. NBC/3/103). This may well be the same individual who is recorded under the name John Bray at Fareham where he married in 1745 and died in 1766 (Fox & Hall 1979, 20). Some uncertainty, however, remains about this individual because of his recorded alias Stephens,

since there are references to pipemakers named John Stephens in Newport in 1736 and 1751 (see below).

#### **CC – COLE, Charles** (*Carisbrooke*)

**Recorded as a pipemaker:** 1851–1861

**Likely to have been pipemaking:** c1845–1865

**Born:** 29 Jul 1827 Godshill; bap. 21 Sep 1827, son of John and Jane Cole (IGI)

**Married:** Jane Eldridge (b. c1832) 6 Feb 1856 at Brixton (IGI)

**Children:** Mary Jane (b. c1856 Brixton), Fanny A (b. c1858 Carisbrooke), William E (b. c1860 Carisbrooke), Sarah A (b. c1862 Carisbrooke), Kate (b. c1864 Carisbrooke), John (b. c1866 Carisbrooke), Emily L (b. c1870 Carisbrooke) (Genes Reunited)

**Died:** 1871 (Q1) aged 44 (FreeBMD)

#### *Census Information*

**1841** – Aged 10 (no occupation given) and living at home in Gunville Lane, Carisbrooke, with his mother Jane (no occupation and age given as 15 but it should have been 55) and siblings Abraham (Ag. Lab, 25), William (Ag. Lab., 20), David (15) and George (8).

**1851** – Aged 22 listed as a tobacco pipe maker apprentice, living at 18 Gunville, Carisbrooke with his widowed mother Jane Cole (65, Char Woman) and siblings Abraham (b. c 1813, Day Lab.), William (b. c 1815, Day Lab.), James (b. c1817, Day Lab.), Jane (b. c 1819, Laundress), George (b. c 1831, listed as a ‘Pauper (Idiot)’), and two children (listed as the grandchildren of his mother Jane), George Cole (9, scholar) and James Jones (2).

**1861** – Aged 33 listed as a journeyman pipemaker living at 6 New Street, Carisbrooke with his wife Jane (29) and children Mary Jane (scholar, 5), Fanny A (scholar, 3) and William E (1).

**1871** – Aged 44 listed as a greengrocer and agricultural labourer living at 122 Town Lane, Newport with his wife Jane (39) and children Mary J (15), Fanny (13), William (11), Sara A (scholar, 9), Kate (scholar, 7), John (scholar, 5) and Emily (1).

Charles was born in 1827 in Godshill, son of John and Jane Cole. He married Jane Eldridge of Brixton in February of 1856 and they had a total of 6 children (Mary Jane, Fanny A, William E, Sarah A, Kate, John and Emily L). Charles is listed as a pipemaker’s apprentice in 1851 while he was still living with his widowed mother and siblings. By 1861 he was working as a journeyman pipemaker but by 1871 appears to have

given up pipemaking and is listed as a greengrocer and agricultural labourer. He died aged just 44 in the second quarter of 1871. He may well have been related to Robert Cole, but the exact relationship is unknown and he may also have been distantly related to John James, since his mother, Jane, had a granddaughter James Jones (age 2) living with her in 1851.

**HC – CAMPBELL, Henry** (*Newport*)

**Recorded as a pipemaker:** 1851

**Likely to have been pipemaking:** +1851+

**Born:** c1835 in Newport

*Census Information*

**1841** – Not found.

**1851** – Aged 16 listed as a pipemaker living in Cosham Street, Newport with his parents John (vintner tramp, 45) and Jane (33) and brother John (11). Also in the house Eliza Ramble (servant, 23) and visitors William Knapp (seaman, 25) and Jane Sweetman (sempstress, 30).

**1861** – Aged 23 listed as a journeyman cabler living in a lodging house in 7 Carvel Lane, Northwood, Cowes.

**1871** – Not found.

Born c1835 in Newport, son of John and Jane Campbell. Henry can only be found in two census records, first in 1851 when he is listed as a pipemaker aged 16. The next record is in 1861 and is assumed to be the same person. By this date he is listed as a journeyman cabler. It seems likely that he was simply employed by a pipemaker in 1851 (or working as an apprentice), and he is not likely to have ever worked on his own account.

**IC – CHAMBERLAIN, James Henry** (*Fareham and Newport*)

**Recorded as a pipemaker:** 1861 (Fareham); 1871–1901 (Newport)

**Likely to have been pipemaking:** 1861–c1915

**Born:** c1848 in Portsmouth

**Married:** Caroline Cottell (b. c1850, Newport) 1871 Q3

**Children:** Martha Ellen (b. Q1 1872, Newport), Caroline (b. c1874, Newport), Harry James (b. Q2 1876, Newport) and Alice Elizabeth (b. Q2 1878, Newport), George Albert (b. Q3 1881, Newport), Alfred Frederick (b. Q1 1883, Newport), Beatrice Daisy (b. Q1 1885, Newport) and Florence Ethel M (b. Q2 1887, Newport) and Arthur Sydney (b. Q2 1899)

**Died:** 1924 Q2, Isle of Wight, aged 75 (FreeBMD)

*Census Information*

**1851** – Aged 2 living at Cross Street, Southampton with parents James (pipemaker, 27) and Martha (21) and brother John (0).

**1861** – Aged 12 listed as a pipemaker living at 1 Wallington Hill, Fareham with his parents James (pipemaker, 37) and Martha (pipemakers wife, 33) and brothers John (scholar, 10) and George (scholar, 8).

**1871** – Aged 23 listed as a pipe maker lodging in Orchard Street, Carisbrooke (Newport) at the home of Hester Cave (66).

**1881** – Age given as 22, [should be 32], listed under the name Henry James as a tobacco pipemaker living at 47 Orchard Street, Carisbrooke (Newport), with his wife Caroline (22 [should be 32]) and children Martha Ellen (scholar 9), Caroline (scholar 7), Harry James (scholar 5) and Alice Elizabeth (3).

**1891** – Aged 41 listed as a general labourer living at 36 Orchard Street, Carisbrooke (Newport), living with his wife Caroline (41) and children Martha H (19) and Henry J (16), Alice E (scholar 13), George E (scholar 10), Alfred (scholar 9), Beatrice Daisy (scholar 6) and Florence E M (scholar 4) and Arthur S (2).

**1901** – Aged 52 listed as a pipemaker under the name of Henry living at 6 Drakes Road, Newport with his wife Caroline (52) and children Henry (navy, 26) George (mason, 19), Alfred (gas fitter, 18), Daisy (16), Flossy [*sic*] (14), and Arthur (12).

**1911** – Aged 63 listed as a general labourer under the name of Henry James living at 6 Drake Road, Newport, with his wife Caroline (58) and his son Alfred Frederick (railway labourer, 26).

Born c1848 in Portsmouth, son of James and Martha Chamberlain. He is first listed as a pipemaker in 1861 whilst still living at home with his parents in Fareham. By 1871 he was lodging in Orchard Street Newport, where he was working as a pipemaker and in early 1871 that he married Caroline Cottell. In 1872 they were living in Pyle Street, Newport, when he was charged with assaulting his wife, “Borough Court, on Monday, before F. Pittis Esq. (chairman), R. Pinnock and F. Vulliamy, Esqs., James Henry Chamberlayne, pipe maker, Pyle-street, was charged with assaulting his wife. Caroline Chamberlayne, who appeared in court with both her eyes blackened, said that on Saturday morning last, while she was washing the child, her husband struck her in the face, knocked her down, and, in rising, he again struck

her and knocked her down. She did not wish to press the charge against her husband, but hoped the magistrates would bind him over to keep the peace towards her. The defendant, after having been severely admonished by the Chairman, was bound over in his own recognizances to keep the peace towards his wife for six months" (*Hampshire Telegraph*, 4 Sept 1872, Issue No. 4179). In the 1881 census his name is given as Henry James and he and his wife had four children and were living at 47 Orchard Street, Carisbrooke (Newport) where he was working as a pipemaker. There appears to be a transcription error over the ages of both James and his wife Caroline, who are both given as being aged 22, which in fact they should have been 32. By 1891 they had had a further four children but James was then listed as a general labourer. By the time of the 1901 census his is once again listed as a pipemaker under the name of Henry Chamberlain. In 1911 he had returned to working as a general labourer. He died in the second quarter of 1924 aged 75.

**RC – COLE, Robert** (*Newport*)

**Recorded as a pipemaker:** 1839–1881

**Likely to have been pipemaking:** c1839–c1885

**Born:** c1817

**Married:** 1. Martha Ruddle (b. c1826, Bishops Canning, Wiltshire; d. Q1 1852 Isle of Wight (FreeBMD)); 2. Sarah Ann Dowson (b. c1826, Newport) Q1 1868 Isle of Wight (FreeBMD)

**Children:** Robert (b. c1849, Newport), Mary (b. c1850, Carisbrooke), Emma (b. c1851, Carisbrooke), John Eaton (b. c1870, Newport)

**Died:** 12 July 1901 (Probate list)

*Census Information*

**1841** – Aged 24 listed as a pipemaker living at the Duke of York Public House in Node Hill, Carisbrooke with James Jacobs (65) and his wife Hannah Jacobs (65), Edward King (journeyman pipemaker, 55) and Henry King (pipemaker, 15).

**1851** – Aged 33 listed as a tobacco pipe maker and cider merchant employing 6 men, 2 boys and 2 women, living at Node Hill, Carisbrooke with his wife Martha (25) and children Mary (1) and Emma J. (7 months) and also a general servant, Fanny Brading (16). At this time Robert's son, Robert R. (2) is visiting his grandparents in Bishops Canning, Wiltshire where he is listed as a pipe manufacturer's son.

**1861** – Aged 43 listed as a widowed cabinet maker employing 4 men and 4 apprentices and

pipemaker employing 4 men and 1 boy, living in Carisbrooke Road, Newport with his children Robert (scholar, 12), Mary (scholar, 11), his mother Mary (proprietor of houses, 65) and house keeper Ann Edwards (35).

**1871** – Aged 53 listed as an auctioneer and cabinet maker employing 2 men and 2 boys living at 2 Carisbrooke Road, Newport with his wife Sarah Ann (45) and son John Eaton (1), his mother Mary (annuitant, 76) and a general domestic servant Sarah Harding (15).

**1881** – Aged 63 listed as a tobacco pipe manufacturer employing 4 men and 1 woman, living in Parade Cottage, Northwood, Cowes with his wife Sarah (55), son John E. (11), mother Mary Cole (annuitant, 88) and a domestic servant Maria Holland (14).

**1891** – Aged 73 listed as a retired farmer living at Elm Cottage, 1 Terminus Road, Northwood, Cowes with his wife Sarah (63) his son John E. (grocers assistant, 21) and a domestic servant Charlotte Troff (16).

**1901** – Aged 83 listed as a retired farmer living at 3 St John's Terrace, Newport with his wife Sarah A (75), his son John E. (grocers clerk, 31) and a domestic servant Etheline Haylester (18).

**1911** – Now deceased, widow Sarah Ann (85) living at 3 Terrace Road, Newport with her son John Eaton (employed in the cycle trade, 41), step-daughter Mary Anne Porachil (61) and domestic servant Emily Wheeler (20).

Robert was born c1817 in Newport. He married twice, first to Martha, who died in the first quarter of 1852, with whom he had three children, Robert, Mary and Emma, and second to Sarah Ann Dowson in 1868 with whom he had just one son, John Eaton. Oswald (1975, 171) lists Robert Cole in trade directories for 1839 to 1878, the earliest reference presumably being from *The Vectis* directory of 1839, which lists him as a pipe maker in Orchard Street. This shows that Cole was already running his own business at this date, despite being only about 22 years old. He may well have taken over the works from John Jones (*q.v.*). Robert Cole first appears in the census records in 1841 when he was living at the Duke of York public house in Node Hill (just round the corner from Orchard Street) and working as a pipe maker, together with Edward King and his son Henry King. In 1844 he is listed as a tobacco pipe maker in Orchard Street, Carisbrooke (Newport) (Pigot Directory for 1844, page 34). By the 1851 census Robert was clearly a successful tobacco pipe maker and cider merchant since he



was living in Node Hill and employing 10 people (6 men, 2 women and 2 boys). He had at least one apprentice in 1849, Edward Prangnell, because the *Hampshire Telegraph* for 31 May of that year reports that Edward was charged with 'absenting himself from his work'. By 1861 Robert has lost his first wife and was living in Newport with two of his children and his mother. At this time he is working as a cabinet maker employing 4 men and 4 apprentices and a pipe maker employing 4 men and one boy. Robert married for a second time in 1868, to Sarah Ann Dowson and appears to have tried to give up the pipemaking business two years later, since the following advert appeared in the *Hampshire Advertiser* on 21 and 24 September 1870: "To pipemakers and others – To be let, with immediate possession, that old-established business, situate in Orchard-street, Newport, Isle of Wight, known as Cole's Pipe Manufactory, together with the house and business thereto belonging. For particulars apply to R. Cole, on the premises; or to Mr. H. R. Hooper, solicitor, Newport, Isle of Wight." It is not known if a tenant was found but, by 1871, Cole had a one-year-old son, John Eaton, and the family were living in Newport, where Robert was described as an auctioneer and cabinet maker. Although he was not listed as a pipemaker at this time, any gap was short-lived since, by 1874, the *Isle of Wight Observer* for 6 June records him demonstrating pipemaking at the Newport Working Men's Exhibition: "Amongst the local industries represented mention should be made of a pipe-making machine, by Mr. Cole. On the days of exhibition a man was engaged in the manufacture of pipes, and the process was watched with great interest." In 1875 he was once again listed in the Post Office Directory as a pipe manufacturer in Orchard Street Newport (PO Dir. Hants, Wilts, Dorset for 1875, page 288). In 1880 Robert was described as a pipe maker when he was the defendant in an unusual case at the County Court in Newport, which was reported in the *Isle of Wight Observer* for 9 October of that year. The plaintiffs were Guiseppe, Angela and Antonia Pompa, Italian wandering minstrels, who were claiming £30 9s. for injuries and damage to their piano-organ on wheels, which had been overturned by the defendant driving a horse and light van in St James' Square, Newport, at about 9pm on the evening of the 3<sup>rd</sup> September. The two women had been performing with their instrument on the road between the drinking fountain and the Lamb Tavern to about 20 people when

Cole drove up and, without giving them time to move, whipped his horse and drove furiously past running over one of the women and overturning the organ. He had to pay £11 plus costs and an interpreter's fee. In the 1881 census he was listed as a pipe manufacturer employing 4 men and 1 woman, living in Northwood, Cowes. This is the last time he is linked with the pipe industry and in 1891 and 1901 his occupation is given as a retired farmer. From other documentary sources it seems clear that James Dyer took over the 18 Orchard Street business from Cole, probably during the 1880s, and certainly by 1891. Dyer then ran the works until his death in 1899, after which it was taken over by Leonard Andrews, c1903/4. Robert Cole died in the first quarter of 1901, aged 84 (FreeBMD). His exact date of death is given in the probate records, which record that Robert Cole of Newport, retired cabinet-maker, died on 12 July 1901, and that the probate was granted to his widow, Sarah Ann Cole, and accountant, John Eaton Cole [his son], on 13 May 1904 (Ancestry.co.uk; accessed 19–8–13). The value of his effects was £200 14s. 3d.

**ID – DOWDEN, James** (*Whippingham, Nr Cowes*)

**Recorded as a pipemaker:** 1841–1867

**Likely to have been pipemaking:** +1841–1867

**Born:** c1818 at Whippingham, Isle of Wight (Genes Reunited)

**Married:** Louisa Frances Dent Q3 1851, Isle of Wight (FreeBMD)

**Children:** George Henry (b. Q1 1853, Whippingham) Robert (b. c1855, Whippingham) William James (b. Q4 1857, Whippingham), John Charles (b. Q4 1858, Whippingham) and Joseph (b. Q4 1860, Whippingham)

**Died:** 1867 (29 March) at Cross Lanes, nr. Newport, aged 49 (*Hampshire Telegraph* for 3 Apr 1867; Issue No. 3613)

*Census Information*

**1841** – Age 13 [this must be a transcription error as he should be 23 at this date but all other family details are correct], no occupation, given living in Fairlee, Whippingham, Cowes with his father James (carpenter, 55) and mother Ann (50) and siblings John (bricklayer, 20) and Robert (tailor's apprentice 15).

**1851** – Aged 33 listed as a pipemaker living in Fairlee Road, Whippingham, Cowes with his father James (carpenter, 62) and mother Ann (58).

**1861** – Aged 43 listed as a tobacco pipemaker living in Coppins Bridge, Whippingham, Cowes with his wife Louisa (34) and children George H (scholar 8), Robert (scholar 6), William J (scholar 4), John C (2) and Joseph (7 months).

Born c1818 in Whippingham, Isle of Wight, son of James and Ann Dowden. He first appears in the 1841 census where no occupation is given, and there seems to be a problem with the transcription of his age, but he is living with his family in Fairlee, Whippingham. He is still with them in 1851, this time aged 33 when he is listed as a pipemaker. He appears to have married at the end of 1851 and started a family. By 1861 he is living in Coppins Bridge, Whippingham, Cowes with his wife and young family. His death aged 49 at Cross Lanes, near Newport, on 29 March 1867 is reported on in the *Hampshire Telegraph* on 3 April of that same year. There is a wood called ‘Tobacco Pipe Copse’ only about a mile SE of Whippingham, which may well be related to pipemaking activity in the area.

**ID – DYER, James** (*Newport*)

**Recorded as a pipemaker:** 1891–1898

**Likely to have been pipemaking:** c1885–1899 (died), with the business sold by c1903/4

**Born:** c1833 Carisbrooke, IOW (Bap. 1 Sept; IGI)

**Married:** Catherine (b. c1836, Ceylon, West Indies (British Subject); 1891 census online)

**Children:** None

**Died:** 1899 (3<sup>rd</sup> quarter) aged 66, IOW (FreeBMD online)

#### *Census Information*

**1841** – Aged 8, living at Dalemores, Whippingham, Isle of Wight with his parents James (55, Ag. Lab.) and Elizabeth (50) and siblings Jane (30), Charlotte (15), Daniel (15, Ap. Blacksmith), Mark (15) and Elizabeth (10).

**1851** – Not found.

**1861** – Aged 26 listed as a brewer’ labourer living at 3 Barrack Street, Portsmouth with his wife Kate (25).

**1871** – Aged 38 listed as a brewer’s labourer living in Barrack Street, Portsmouth with his wife Kate (37) and his widowed sister Jane Chissell (63).

**1881** – Aged 47 listed as a stonemason living at 2 Barrack Street, Portsmouth with his wife Catherine (45).

**1891** – Aged 52 listed as a tobacco pipe manu-

facturer living at 18 Orchard Street, Carisbrooke (Newport) with his wife Catherine (55).

James was baptised at Carisbrooke on 1 September 1833 (IGI) and was probably the youngest son of James and Elizabeth Dyer, both from the Isle of Wight, who had had at least six children from 1808 onwards (1841 CR). In 1841 James Sr. was an agricultural labourer living with the six children in Cowes and, in 1851, he was an agricultural labourer and innkeeper in Cowes, by which time all the children had left home. James Jr. has not been found in the 1851 census but, by 1861 he had married Catherine (Kate), who was born in Ceylon c1834/6. In the 1861–1881 census records they are listed living in Barrack Street, Portsea Island, Portsmouth, and they do not appear to have had any children. In 1861 and 1871 James Jr. is listed as a brewer’s labourer and, in 1881, as a stonemason. In 1871 his widowed sister, Jane Chessell (born c1808), was also living with them. The first reference to James as a “tobacco pipe manufacturer” is in the 1891 census, by which time he and Catherine were living at 18 Orchard Street, Carisbrooke (Newport). The fact that he was described as a ‘manufacturer’ suggests that he was probably employing others, although this is not specifically stated in the census returns. 18 Orchard Street was an important pipe making address in Carisbrooke, where Robert Cole (recorded as a pipe maker from 1839–1881) had previously been running a business employing several people. Cole (born c1818) had retired by 1891 and so Dyer must have returned to the island to take over his business, most likely during the mid-1880s. It is not known how Dyer came to be involved with the pipe trade but he may come across it in connection with his father’s trade as an innkeeper and/or while working as a brewer’s labourer. Dyer is listed as a pipe maker in trade directories of 1895 and 1898 but appears to have died in the third quarter of 1899. His widow has not been traced in the 1901 census but the business subsequently passed to Leonard Andrews, who was listed at 18 Orchard Street in the 1911 census. Andrews had previously been working as an estate agents cashier and accountant in Cambridgeshire, where he was listed in 1901. His first two children (born c1901 and c1903) were born in Cambridgeshire but, from c1904 onwards, they are listed as having been born in Newport, which clearly suggests that he had taken over the pipe works by c1903/04. From the documentary sources it seems clear that Dyer took over the 18 Orchard

Street business from Cole, probably during the 1880s, and certainly by 1891. He then ran it until his death in 1899, after which it was taken over by Andrews, c1903/4. He produced pipes with his initials JD moulded on the heel, which can be closely dated to this period.

**EE – EDGAR, Edward** (*Bristol, Burnley, Southampton, Newport and Southwark*)

**Recorded as a pipemaker:** 1861 (Bristol), 1871 (Burnley), 1881 (Southampton), 1891 (Newport), 1901–1911 (Southwark)

**Likely to have been pipemaking:** c1860–1911+

**Born:** cJan 1843 (bap. 26 Feb 1843)

**Married:** Sarah Ann Davis (b. c1843–5, Worcester) Q4 1870 in Madeley (Price 2013)

**Children:** Emily (b. Q1 1871, Worcester), Thomas (b. Q1 1873, Southampton), Ellen (b. Q4 1874, Southampton) (Price 2013), plus two other children who did not survive (1911 Census)

#### *Census Information*

**1851** – Aged 11 listed as a juvenile, living in Great Anne Street, Clifton, Gloucester, with his parents Thomas (pipemaker, 42) and Hannah (pipemaker, 47), siblings James (pipe maker, 23), Ann Offer (pipemaker, 28 and her daughter Hannah (1)), Thomas (pipemaker, 12), Elizabeth (pipemaker, 7) and a lodger George Hadder (pipemaker, 21).

**1861** – Aged 18 listed as a pipemaker one of five men lodging in the house of John Buss (a baker) Great Ann Street.

**1871** – Aged 26 listed as a pipe finisher, married and lodging in the house of Robert Thornton (finisher – presumably pipe, 60) at Blackburn Street, Burnley. In the same household are John Heyes (pipemaker, 30), Ann Heyes (pipemaker, 32). At this time Edgar's wife Sarah (Governess, 32) and daughter Emily (0) are visiting Richard and Ann Davis in Waterloo Street, Worcester, who were presumably her parents.

**1881** – Aged 37 listed as an artisan pipemaker living at 3 Cross Court, All Saints, Southampton with his wife Sarah A (finisher, 36) and children Emily (scholar, 10), Thomas (scholar, 8) and Ellen (6).

**1891** – Aged 47 listed as a pipemaker living at 28 Portland Street, Newport, with his wife Sarah (45), son Thomas (railway porter, 18) and daughter Nelly (dressmaker, 16).

**1901** – Aged 57 listed as a clay pipemaker living at 177 Brook Street, Southwark with his wife

Sarah (58), his son Thomas (gas worker, 28) and daughter Nellie (dressmaker, 24).

**1911** – Aged 67 listed as a wholesale clay pipemaker living at 177 Brook Street, Southwark with his wife Sarah (65).

Edward was born about Jan 1843, the son of Thomas and Hannah Edgar, in Great George Street, Bristol, and baptized on 26 Feb 1843 at St Philip's. He appears to have spent most of his life working as a pipe maker but was clearly a journeyman travelling all over the country to ply his trade. He first appears in the 1851 census aged 11 living in Gloucester with his pipemaking parents, Thomas and Hannah. Four of his siblings are also engaged in production at this time as is the lodger, George Hadder, who is also living with the family. By 1861 Edward is still in Gloucester and working as a pipemaker but is lodging in the house of John Buss, Baker with five other men. Around 1870 Edward married Sarah Ann Davis who was born in Worcester. At the time of the 1871 census Edward is living in Burnley where he is working as a pipe finisher, his wife Sarah and their daughter Emily are living in Worcester with Sarah's parent. In 1881 Edward has moved his family to Southampton where he is working as a pipemaker. He is still a pipe maker in 1891 but by now they have moved to Newport and by 1901 they have move to Southwark. The family are still in Southwark in 1911 at which time Edward is described as a wholesale clay pipemaker. Edward was the Uncle of James Edward Edgar (*q.v.*).

**JE/EE – EDGAR, James Edward** (*Portchester and Newport*)

**Recorded as a pipemaker:** 1881 (Gloucester); 1901 (Portchester); c1904–1938 (Newport)

**Likely to have been pipemaking:** c1881–1938

**Born:** c1865 Bristol

**Married:** Alice Hayes (nee Jackson) (b. c1866 Fareham; d. Q4 1924 Fareham) 7 Dec 1895 at Holy Trinity Church, Fareham (Knightsroots)

**Children:** None

**Died:** Died Q1 1939 at Gloucester, aged 74 (FreeBMD)

#### *Census Information*

**1871** – Aged 6, under the name James E, living in 8 New Street, Gloucester with his parents James W Edgar (pipemaker 49) and Mary A (bag maker 38) and sisters Martha (pipemaker 17) and Kate (2).

**1881** – Aged 15, tobacco pipe maker under the name James, living at 19 Wellesley Street, Gloucester with his parents James Edgar (tobacco pipe maker 53) and Mary Ann (48) and sister Kate (scholar 11). Also with the family is a charwoman, Charlotte Moss (54).

**1891** – Not found

**1901** – Aged 36, under the name Edward J, listed as a clay tobacco pipe maker living in Castle Street, Portchester with his wife Alice (35).

**1911** – Aged 46, under the name Edward James listed as a clay pipe maker living at 17 High Street, Newport with his wife Alice (45) and a boarder Arthur Cooper (carter, 20).

Edward was born in 1865 son of James and Mary Newton, in Bristol into an extensive pipe making dynasty. He was born James Edward and appears to have used that for the early part of his life. By the time of his marriage in 1895 to Alice Hayes he had chosen to use his middle name and from this time, until his death, he appears in all the records as Edward James. He first appears in the 1871 census aged 6 living with his family in Gloucester. He is still living with them in 1881 but now, aged 15, he is working as a tobacco pipe maker with his father. He cannot be traced in the 1891 census, but by 1901 he is married and living in Porchester with his wife Alice working as a clay tobacco pipe maker. One of his obituaries (see below) notes that he moved to Newport in about 1904, where he initially worked at the factory in Orchard Street, before setting up his own business. There is reference to him in the *Edinburgh Gazette* for 19 May 1908 when he is listed as a dealer in 'hearthstone pipe clay &c' at 17 High Street, Newport, Isle of Wight (<http://www.edinburgh-gazette.co.uk/issues/12039/pages/555/page.pdf>), which shows that the new business in the High Street was established by this date. At the time of the 1911 census, Edward and Alice are recorded living at 17 High Street, Newport. At this date Edward also appears in Kelly's Directory as a 'tobacco pipe manufacturer' (Historical Directories online). He continues to be listed in trade directories for Newport from 1923 to 1931 (Oswald 1975, 172). Kelly's 1927 directory has been seen, and this lists him as a 'tabacco pipe mkr.' [*sic*] at 17 High Street, Newport. The obituaries (below) show that he worked there until c1938 when he retired, the last pipe maker on the Isle of Wight. His death is recorded in the first quarter of 1939 in Gloucester (FreeBMD). Two obituaries of 1939 cut from a unnamed local papers survive

in Carisbrooke Castle Museum and provide a lot of useful detail about his life and trade. The first of these (D.1986.2896.104) says, "Death of Mr. J. Edgar. – A familiar figure in the town, Mr. James Edward Edgar, who for many years was a clay pipe maker at 17 High-street, passed away at Gloucester and was buried there on Thursday. He gave up his business about a year ago [c1938] and went to live in retirement with relatives at Gloucester, but he returned on a visit during the autumn. Mr. Edgar, who was 74, came to the town about 35 years ago [c1904] as a pipe maker to a firm which then carried on the industry in Orchard-street, but after a few years he started making clay pipes on his own account at 17 High-street and, although the demand for "churchwardens" was a dwindling one, as smoking fashions changed to the cigarette and the superior looking briar, he was kept fairly busy to the last at his unusual calling, of which he was a master. Mr. Edgar was the third generation of his family engaged in that trade. His grandfather was foreman of the largest clay pipe factory in England at Bristol. The firm at that time had their own ships to deal with a large export trade to the continent. In his later days at Newport Mr. Edgar's productions were confined to "R.A.O.B." pipes and those with fancy faces which were still somewhat in demand among elderly folk who preferred them when smoking in the seclusion of their homes. As a young man Mr. Edgar served in the Hampshire Regiment, seeing active service in the Burmese War, and for many years he was a popular member of the Newport companies of the I.W. Rifles, being a splendid worker as a corporal in the cookhouse during annual trainings. His many business and Territorial friends in the town will regret to hear of his death. He was a good comrade and a man whose quiet industry and generous nature won him much esteem." The second cutting (D.1986.2896.105) reads, "Clay pipe making, once a flourishing industry at Newport, has now died out, owing to the dwindling demand for clays in these days of briars and cigarettes. The last of the Newport clay pipe makers (Mr. James Edgar) passed away a few days ago at Gloucester, where he was living in retirement with relatives. He was a very clever clay pipe maker, the third generation of his family to follow the calling, and there was still sufficient demand for his productions to keep him employed until he retired about a year ago [c1938]. In conversation with the writer a few years ago Mr. Edgar said that some 30 years ago, when he came to work at a clay pipe factory in

Orchard-street, Newport, there was still a good trade being done with France, but it gradually died away. "However, I still turn out a few for the R.A.O.B.," remarked Mr. Edgar. Asked why he thought clays had gone out of favour, he replied: "Because they are too cheap. They are fine pipes, and some people still know it, but they won't be seen smoking one. Still, more people than you would think smoke them indoors, where no one can see them." Mr. Edgar was not ashamed of his productions; he always smoked one indoors and out. He had some rare moulds for making fancy clay pipes, which were family heirlooms. They would make interesting exhibits in the Island Museum as evidence of a local industry which has ceased to exist."

## II – JONES, John (*Newport*)

**Recorded as a pipemaker:** 1832–1841

**Likely to have been pipemaking:** c1781–c1841

**Born:** c1760 Hampshire (1841 Census)

**Died:** Either Q1 1842 or Q3 1847 (FreeBMD)

### *Census Information*

**1841** – Aged 80 listed as pipe maker living Orchard Street, Carisbrooke (Newport) with Ann Mulholland (grocer 45) and her daughter Ann (14).

John can only be traced in the census records for 1841 when he is listed as a pipemaker aged 80 and living in Orchard Street, Carisbrooke (Newport), next door to John Munday (pipemaker, 35). From the census it is possible to calculate his approximate year of birth as c1760. The only other references to him relate to his activities as a keen gardener. He appears, listed as a pipemaker, in the *Hampshire Telegraph* twice, first in 1832 when he won second prize in the Newport Annual Dahlia Show (*Hampshire Telegraph* for 10 Sept 1832; Issue No. 1718) and then again in 1833 when he won first prize at the Nodehill Annual Pink Show (*Hampshire Telegraph* for 24 June 1833; Issue No. 1759). It is most likely that he is one of two John Jones's who died on Isle of Wight, the first in Q1 1842 and the second in Q3 1847. Pipes marked II are known and so this individual probably worked as a master pipe maker, most likely running the Orchard Street works prior to its being taken over by Robert Cole, c1839. He may also have been related to the Cole family, since Charles Cole's mother, Jane, had a granddaughter James Jones (age 2) living with her in 1851.

## EK – KING, Edward (*Newport*)

**Recorded as a pipemaker:** 1841 (Newport); 1851–1861 (Southampton)

**Likely to have been pipemaking:** +1841–1861+

**Born:** c1785 St Marys, Southampton

**Married:** Charlotte (b. c1784 St Helens, Isle of Wight)

**Children:** Henry (b. c1826)

### *Census Information*

**1841** – Aged 55 listed as a pipe maker living at the Duke of York public house run by James and Hannah Jacobs in Nodehill, Newport, with his son Henry King (pipe maker, 15) and Robert Cole (pipe maker 24).

**1851** – Aged 67 listed as a pipe maker living at 21 Winchester Terrace, Southampton, with his wife Charlotte (61) in the home of their daughter Caroline Dyer (laundress, 33). Also in the house are two visitors John Pubben (domestic servant, 57) and William Atkins (turner and French polisher, 22).

**1861** – Aged 72 listed as a pipe maker lodging in Winchester Terrace, Southampton.

**1871** – Not found.

Edward was born c1785 in Southampton but first appears in Newport at the time of the 1841 census when he is working as a pipemaker together with his son Henry and also Robert Cole. By 1851 he and his family have moved to Southampton where he continues to work as a pipemaker. Ten years later, aged 72, he is still in Southampton and recording his occupation as a pipemaker.

## HK – KINGSWELL, Henry (*Newport*)

**Recorded as a pipemaker:** 1709

**Likely to have been pipemaking:** 1709+

1709 – Elizabeth Stephens of Newport, widow, and Edward Stephens (her son) of Newport, tobacco pipemaker, took Henry Kingswell apprentice on 3 Feb 1709 (NBAI Ref. NBC/3/53).

## HK – KIRBY, Henry (*Portsmouth and Carisbrooke*)

**Recorded as a pipemaker:** 1841–1851 (Portsea, Portsmouth); 1871–1881 (Carisbrooke)

**Likely to have been pipemaking:** +1841–1887

**Born:** c1812 Newport, Hampshire

**Married:** Anna (b. c1809 Ryde, Hampshire)

**Children:** Ellen (b. c1836, Ryde, Hampshire), Sarah (b. c 1839 Kingston, Hampshire), Caroline (b. c1843, Kingston, Hampshire), Henry (b.

c1846, Kingston, Hampshire) Albert (b. c1850, Kingston, Hampshire), Alice (b. c1850, Kingston, Hampshire) Joseph (b. c1853)  
**Died:** Q2 1887 Isle of Wight, aged 76 (FreeBMD)

*Census Information*

**1841** – Aged 30 listed as a pipe maker living at Cottage View, Portsea, Portsmouth with his wife Hanah [*sic*] (30) and children Ellen (5) and Sarah (2) in the home of David and Mary Dominey and family.

**1851** – Aged 41 listed as a pipe maker living in Radnor Street, Portsea, Portsmouth with his wife Anna (42) and children Ellen (assistant to father, 15), Sarah (12), Caroline (8), Henry (5), Albert (1), Alice (1).

**1861** – Aged 49 listed as a pipe maker living in Clarendon Street, Carisbrooke with his wife Ann (43) and children Henry (errand boy, 14), Albert (scholar, 11), Alice (scholar, 11) and Josiah (scholar, 8).

**1871** – Aged 61 listed as a pipe maker living in Clarendon Street, Carisbrooke with his wife Ann (53) and his sons Albert (general dealer, 21) and Joseph (baker, 18).

**1881** – Aged 69 listed as a master tobacco pipe maker living in Clarendon Street, Carisbrooke with his wife Ann (64).

Henry Kirby was born in Newport c1812. At the time of the 1841 and 1851 censuses he was living in Portsea, Portsmouth with his wife and children working as a pipe maker. In 1861 and 1871 the family was living in Carisbrooke on the Isle of Wight. By 1881 he is listed as a master pipemaker. Henry died in the second quarter of 1887 on the Isle of Wight aged 76.

**HK – KING, Henry** (*Newport*)

**Recorded as a pipemaker:** 1841

**Likely to have been pipemaking:** +1841+

**Born:** c1826

*Census Information*

**1841** – Aged 15 listed as a pipe maker living at the Duke of York public house run by James and Hannah Jacobs in Nodehill, Newport with his father Edward (pipe maker, 55) and Robert Cole (pipe maker 24).

**1851** – Not found.

Henry can only be traced in the 1841 census when he is listed as a pipemaker working with his father in Newport. It seems most likely that he either died young or went on to pursue another career.

**WK – KIRBY, William** (*Newport*)

**Recorded as a pipemaker:** 1841

**Likely to have been pipemaking:** +1841+

**Born:** c1756 Hampshire

**Married:** Mary (b. c1761 Hampshire)

**Census Information**

**1841** – Aged 80 listed as a pipemaker living in Church Lane, Newport with his wife Mary (80) and Henry Kirby (6) presumably a grandson.

**AM – MOREY, Ann** (*Carisbrooke*)

**Recorded as a pipemaker:** 1851 (pipe trimmer)

**Likely to have been pipemaking:** +1851+

**Born:** c1819, Carisbrooke

**Married:** Edwin (b. c1817 Gunville)

**Children:** Frank Edwin (b. c1838, Carisbrooke), Matthew Henry (b. c1840, St Olives [*sic*], London), Thomas John (b. c1842 Bermondsey, London)

**Died:** Q1 1873 Isle of Wight (FreeBMD)

*Census Information*

**1841** – Not found.

**1851** – Aged 32 listed as a pipe trimmer living in Gunville, Carisbrooke with her husband Edwin (pipe maker, 34) and children Frank Edwin (pipe maker, 13), Matthew Henry (scholar, 11), Thomas John (scholar, 9). Also with Hannah Morey (mother-in-law, 68) and Martha Morey (sister-in-law, 20).

**1861** – Aged 42 living in Forest Side, Carisbrooke with her husband Edwin (clerk in a potato store, 44) and son Thomas J (carpenters apprentice, 19) and Sarah Mincey (nursechild, 8).

**1871** – Aged 52 living in New Street, Carisbrooke with her husband Edwin (potato merchant, 54) and Sarah Makstee (a servant, 18).

The 1851 census is the only time that Ann is linked to the pipe industry and was clearly working with her husband and son who were also only linked to the pipe industry at this time.

**EM – MOREY, Edwin** (*Carisbrooke*)

**Recorded as a pipemaker:** 1851

**Likely to have been pipemaking:** +1851+

**Born:** c1817 Gunville (Oswald 1975, 172)

**Married:** 1. Ann (b. c1819, Carisbrooke; d. Q1 1873 Isle of Wight); 2. Sarah Harvey (b. c1827 Fresh Water, Hampshire) Q1 1874 Isle of Wight

**Children:** Frank Edwin (b. c1838, Carisbrooke), Matthew Henry (b. c1840, St Olives [*sic*],

London), Thomas John (b. c1842 Bermondsey, London)

**Died:** Q3 1883 Isle of Wight aged 67 (FreeBMD)

*Census Information*

**1841** – Not found.

**1851** – Aged 34 listed as a pipe maker living in Gunville, Carisbrooke with his wife Ann (pipe trimmer, 32) and children Frank Edwin (pipe maker, 13), Matthew Henry (scholar, 11), Thomas John (scholar, 9). Also with Hannah Morey (mother-in-law, 68) and Martha Morey (sister, 20).

**1861** – Aged 44 listed as a clerk in a potato store living in Forest Side, Carisbrooke with his wife Anne (42) and son Thomas J (carpenters apprentice, 19) and Sarah Mincey (nursechild, 8).

**1871** – Aged 54 listed as a potato merchant living in New Street, Carisbrooke with his wife Ann (52) and Sarah Makstee (a servant, 18).

**1881** – Aged 64 listed as a “Councillor of Borough of Newport Income derived from Lands and Houses”, living at 42 New Street, Carisbrooke, with his second wife Sarah (54) and a lodger Jabez Drew (Bible Christian minister of Quay St Chapel, Newport, 26).

Edwin was born in Newport c1817 but the first time he appears in the census records in 1851 when he is listed as a pipemaker. At this time both his wife and eldest son are also involved in the pipe trade. This is the only time any of them are linked to the pipe industry. Edwin’s son Frank Edwin goes on to become a greengrocer. In the 1861 and 1871 census his occupation is given as clerk in a potato store and potato merchant respectively. By 1881 he is a councillor. He married twice, first to Ann and they had three children. Ann died in the first quarter of 1873 and in 1874 he remarried. His second marriage, to Sarah, took place in the first quarter of 1874. Edwin died in the third quarter of 1883 aged 67.

**FM – MOREY, Frank Edwin** (*Carisbrooke*)

**Recorded as a pipemaker:** 1851

**Likely to have been pipemaking:** +1851+

**Born:** c1838, Carisbrooke son of Edwin and Ann Morey

*Census Information*

**1841** – Not found.

**1851** – Aged 13 listed as a pipe maker living in Gunville, Carisbrooke, with his parents Edwin (pipe maker, 34) and Ann (pipe trimmer, 32) and

siblings Matthew Henry (scholar, 11), Thomas John (scholar, 9).

**1861** – Aged 24, married to Mary and working as a greengrocer in Portsea.

The 1851 census is the only time that Frank is listed as a pipe maker when he was aged 13 and living with his parents, both of whom were pipemakers (and whom he was presumably helping). By 1861 he had married, moved to Portsea and was working as a greengrocer. He was back on the island by 1871, when he was listed as a fruit and corn merchant and then a farmer of 86 acres in 1881 and an agriculturalist in 1891.

**IM – MUNDEY, John** (*Newport*)

**Recorded as a pipemaker:** 1841–1851

**Likely to have been pipemaking:** +1841–1855

**Born:** c1806 in Carisbrooke

**Married:** Jane (b. c 1808)

**Children:** Alfred (b. c1827), Sarah Jane (b. c1841)

**Died:** Probably the John Munday who died Q3 1855 Isle of Wight (FreeBMD)

*Census Information*

**1841** – Aged 35 listed as a pipe maker living in Orchard Street, Carisbrooke (Newport) with his wife Jane (33) and children Alfred (14) and Sarah Jane (0).

**1851** – Aged 45 listed as a pipe manufacturer living in Gunville, Carisbrooke with his wife Jane (43) and daughter Sarah Jane (scholar 10).

John Munday was born in Carisbrooke c1806. He first appears in the 1841 census when he is listed as a pipemaker and living with his family in Orchard Street Newport next door to John Jones (pipemaker, 80). He is possibly the same individual mentioned in the *Hampshire Telegraph* in 1850 when Charles Jackman was sentenced to one month’s imprisonment for stealing a gold pin from him (*Hampshire Telegraph* for 19 Oct 1850; Issue No. 2662). By 1851 John and his family have moved to Gunville, Carisbrooke where he is listed as a pipe manufacturer. He cannot be traced in the 1861 census and by 1871 he had definitely died, since his wife is listed in the census of that year as a widow living in Ryde with her married daughter (Sarah Jane) and her family. It is therefore probable that he is the John Munday whose death is recorded on the Isle of Wight in the third quarter of 1855.

**RM – MAYNE, Richard (I)** (*Newport*)

**Recorded as a pipemaker:** 1826–1827 (Newport); 1841–1844 (London)

**Likely to have been pipemaking:** +1826–1844+

**Born:** c1796

**Married:** not known

**Children:** Possibly Richard (b. c1826, Newport)

The earliest reference to Richard Mayne as a pipemaker on the Isle of Wight is in the *Hampshire Chronicle* for 27 February 1826, when he was amongst a list of insolvent debtors to be heard at Winchester on 22 March; “Richard Mayne, late of Newport, in the Isle of Wight, in the county of Hants, tobacco pipe-maker.” This suggests that he had already become bankrupt and ceased trading prior to February 1826. The *Hampshire Chronicle* for 27 March 1826 notes that he had been examined and discharged, but he does not appear to have been able to carry on the business since the *Hampshire Telegraph* for 29 Jan 1827 advertises; “A piece of freehold land, with pipe kiln. To be sold at auction, by Mr Francis Pittis, on Tuesday, the 30<sup>th</sup> day of January, 1827, at the Shoulder of Mutton Inn, Cosham-street, (by order of the Assignee of Richard Mayne, late of Newport, tobacco pipe maker, an insolvent debtor). The undermentioned freehold land, with pipe kiln thereon, situate near the Gas Works, in Cosham Street; containing in width near the street, 13ft 6in and in depth, 80ft and in breadth, at the north part 50ft late in the occupation of the said Richard Mayne. Immediate possession will be given. For particulars, apply to Mr. Spain, solicitor, Fareham; or to Mr. John Willington, Newport, Isle of Wight. The sale will commence precisely at six o’clock in the evening.” This reference is particularly interesting since it suggests that the kiln was located on a plot of land without any other dwelling or workshop buildings. It is possible that the Richard Mayne referred to is the same individual who turns up in London at the time of the 1841 Census. Aged 45 he was listed as a pipemaker and living in Little Clarendon Street, St Pancras, Middlesex with James Smith (builder, 55) and Michael McEvoy (dairyman, 25). But living with a few doors of Richard are a number of other pipemakers including John Hedges (38), Thomas Smith (29), John Longworth (35), James Gibbs (19) and George Calloway (20). Richard’s place of birth on the 1841 census is not given other than to record that he was not born in the county (i.e., Middlesex). He is listed as a pipemaker in the church register when his son Richard Caslake Mayne married Elizabeth Russell, daughter of

the pipemaker Thomas Ralph Russell, on 2 December 1844 at Trinity Church in the parish of St Andrews, Holborn. It has not been possible to trace Richard (I) further in the census returns and no death record can be found. It seems most likely that having been made insolvent in Newport, Richard (I) moved his family to London where he continued to work as a pipemaker. His son, Richard (II) also took up pipemaking (*q.v.*) and worked as a pipemaker in the Holborn area of London from c1851–1881.

**RM – MAYNE, Richard (II)** (*London*)

**Recorded as a pipemaker:** 1844–1881 (London)

**Likely to have been pipemaking:** +1844–1881+

**Born:** c1821–1826, Newport

**Married:** 1. Elizabeth (b. c1825, St Lukes, Middlesex) 2 December 1844 at Trinity Church in the parish of St Andrews, Holborn (Ancestry); 2. Anie [*sic*] b. c1827, Bethnal Green, Middlesex)

**Children:** None

*Census Information*

**1841** – Not found.

**1851** – Aged 25 listed as a tobacco pipe maker living in New Square, Clerkenwell with his wife Elizabeth (26).

**1861** – Not found.

**1871** – Aged 44 listed as a tobacco pipe maker in Pear Tree Street, St Lukes, Holborn with his wife Elizabeth (46).

**1881** – Aged 60 listed as a tobacco pipe maker living at 34 Waterloo Street, St Lukes, Finsbury with his wife Anie (59).

**1891** – Not found.

Richard Caslake Mayne is listed in the census returns as having been born c1821–26 in Newport, Isle of Wight, and was presumably the son of Richard (I). He is first recorded as a pipemaker on his marriage record on 2 December 1844 when he married Elizabeth Russell, the daughter of the pipemaker Thomas Ralph Russell. In the 1851 census Richard (II) is aged 25 and listed as a tobacco pipe maker. He cannot be found in the 1861 census, but turns up again in 1871 when Richard and his wife are living in St Lukes, Holborn. Richard (44) is still listed as a tobacco pipe maker. In the census return for 1881 Richard’s place of birth is given as Newport, rather than simply Isle of Wight as in the returns for 1861 and 1871. In 1881 he was 60 years old and listed as a tobacco pipe maker living with his wife, possible a second wife as her name is given



as Anie [*sic*] and she is now a year younger than Richard. It has not been possible to trace Richard (II) further in the census returns and no death record can be found.

**EP – PRANGNELL, Edward** (*Newport*)

**Recorded as a pipemaker:** 1849

**Likely to have been pipemaking:** +1849+

**Born:** c1832 Hampshire, son of Edward and Charlotte Prangnell

*Census Information*

**1841** – Aged 9, no occupation is given, living in Orchard Street with his parents Edward (brewer, 25) and Charlotte (25) and siblings Frederick (7), Ann (4) and Fanny (1). It seems likely that he was the nephew of William Prangnell (see below) who was living next door at the time.

**1851** – Aged 18, no occupation is given, living in Orchard Street with his parents Edward (Brewer master, 37), Charlotte (39) and siblings Fredrick (16), Ann (14), Fanny (11) Charlotte (9), Harriett (7), Emily (5) and Ernest (3).

Edward is listed in the 1841 census aged 9 when no occupation is given but is likely that he is the same person who is named in a newspaper report from 1849 as an apprentice to Robert Cole; “Edward Prangnell, an apprentice to Mr. Robert Cole, pipe maker, was charged with absenting himself from his work. The magistrates gave the boy a reprimand and some good advice, and his master agreed to give him another trial” (*Hampshire Telegraph*, 31 Mar 1849, Issue No. 2582). No occupation is given for him in the 1851 census when he was still living with his parents in Orchard Street. He cannot be found with certainty in the 1861 census, but it is possible he was the Edward Pragnall who was married and working as a joiner in Portsea. He is likely to have been the nephew of William Prangnell (*q.v.*), who also worked as a pipemaker in Orchard Street.

**WP – PRANGNELL, William** (*Newport*)

**Recorded as a pipemaker:** 1841–1851

**Likely to have been pipemaking:** +1841–1851+

**Born:** c1821–1823 Newport

**Married:** Maria Lowe (b. c1829) Q3 1851 (FreeBMD) [*at the time of the marriage William’s name is spelt Prangnell*]

**Children:** Rose Ellen (b. Q1 1853 Newport), William A (b. c1855 Newport).

**Died:** Q4 1870 Isle of Wight aged 50 (FreeBMD)

*Census Information*

**1841** – William Prangnell (*sic*), aged 18, listed as a pipe maker living in Orchard Street, Carisbrooke (Newport) in a household with other members of the Prangnell family; Charles (brewer, 30), Elizabeth (30), Mary Jane (8), Catherine (5), and John (20). All born in the county.

**1851** – William Pragnell (*sic*), aged 30, born Newport, listed as a widowed pipemaker living in Orchard Street, Carisbrooke with his widowed father Matthew, born Arretton (coal merchant’s yardman, 71).

**1861** – William Pragnell (*sic*), aged 40, listed as a brewer living in Orchard Street, Carisbrooke living with his wife Maria (32) and children Rose E. (scholar, 8), William A. (scholar, 6) and a visitor Charles Allen (10).

William was born in c1821–1823 in Newport and came from a brewing family. In 1841 his father, Matthew, was listed as a brewer in Orchard St (age 60) living with his mother, Mary, and another brewer, Edward Prangnell, 25, his wife Charlotte (25) and their four children, Edward (9), Frederick (7), Ann (4) and Fanny (1). It seems likely that Edward Sr, was Matthew’s son, as were probably Charles (brewer, 30) and John (20) next door, with whom William was living. He had married and been widowed by 1851, when he was back living with his widowed father in Orchard Street, but still working as a pipemaker. By the time of the 1861 census he was still living in Orchard Street but his occupation was then given as a brewer and he was living with his wife Maria and a young family. He died in the fourth quarter of 1870, aged 50. William is likely to have been employed as a pipemaker by Robert Cole in the Orchard Street works during the 1840s and 50s, before returning to the family brewing trade later in life.

**AR – RILEY, Ann** (*Newport*)

**Recorded as a pipemaker:** 1861

**Likely to have been pipemaking:** +1861+

**Born:** c1836 Newport, Hampshire

**Married:** Not known

**Children:** Emily (b. c1858, Newport), Charles (b. c1860, Newport)

*Census Information*

**1851** – Not found.

**1861** – Age 25 listed as a tobacco pipe trimmer living in Pyle Street, Newport, with her children Emily (scholar, 3) and Charles (1).

**1871** – Not found.

Ann Riley only appears in 1861 to be linked to the pipe trade when she is living in Pyle Street, Newport, working as a pipe trimmer. Although she is listed as married, no husband can be traced, nor can any marriage record. It has not been possible to locate Ann or her children in any of the subsequent census returns.

**IR – ROTHENBURG, John** (*?Isle of Wight*)

**Recorded as a pipemaker:** 1851 Stepney

**Likely to have been pipemaking:** +1851+

**Born:** c1802, Middlesex

**Married:** Ann (b. c1802, Ham, Surrey)

**Children:** Henry (b. c1837, Isle of Wight), Emma (b. c1839, Stepney), William (b. c1841, Bromley), John (b. c1846, Croydon)

*Census Information*

**1851** – Aged 49 listed as a tobacco pipe maker living in Swan Court, Mile End Old Town, Stepney, with his wife Ann (tobacco pipe maker, 49) and children Henry (tobacco pipe maker, 14), Emma (12), William (10) and James (5).

**1861** – This and subsequent census records not checked.

John was born in Middlesex c1802 and subsequently recorded working in London in the census returns, but was probably working on the Isle of Wight in about 1837, since this is where his first son, Henry, was born. The fact that his children were all born in different places strongly suggests that he worked as an itinerant journeyman.

**AS – SAUNDERS, Alfred G** (*Carisbrooke*)

**Recorded as a pipemaker:** 1881–1891

**Likely to have been pipemaking:** +1881–1891+

**Born:** c1858, Carisbrooke, Hampshire

**Married:** Mary Ann Dunne (b. c 1860 Colchester, Essex) Q2 1881 Isle of Wight (FreeBMD)

**Children:** Alfred Thomas (b. c1883, Newport), Margaret (b. c1885), Alice (b. c1887, Newport), Frederick George (b. c1888, Newport), John (b. c1890, Newport), Albert (b. c1897, Newport)

**Died:** Q2 1931 Isle of Wight aged 74 (FreeBMD)

*Census Information*

**1861** – Not found.

**1871** – Not found.

**1881** – Aged 23 listed as a tobacco pipe maker lodging in Trafalgar Road, Carisbrooke with Margaret Dunne (beer retailer, widow, 50) and her daughters Mary Dunne (dress maker, 21) and

Kate Dunne (unemployed domestic servant, 16). With his fiancé Mary, her mother and sister.

**1891** – Aged 32 listed as a tobacco pipe manufacturer living in South View, Carisbrooke with his wife Mary Ann (31) and children Alfred Thomas (scholar, 8), Margaret (scholar, 6), Alice (scholar, 4), Frederick (3) and John (1).

**1901** – Aged 43 listed as a navy living in Union Street, Newport with his wife Mary A (dressmaker 42) and children Alfred T (groom, 18), Frederick (13), John (10), Albert (4).

**1911** – Aged 53 listed as a builders labourer living at 3 New Cottages, Robin Hood Street, Newport with his wife Mary Ann (51) and children George Frederick (green grocer porter, 23) and John (general labourer, 20).

Alfred was born in Carisbrooke c1858. He cannot be traced with certainty in the 1861 or 1871 census, but first appears in 1881 when he is lodging in Carisbrooke with the Dunne family, working as a pipemaker. That same year he marries the daughter of his landlady, Mary Ann Dunne. By 1891 Alfred and Mary have four children. Alfred is working as a pipemaker in Carisbrooke. This is the last time he is linked to the pipe trade. By 1901 the family have moved to Newport and Alfred is working as a navy. By 1911 he is working as a builder's labourer. At the time of the 1911 census it is recorded that three of Alfred and Mary's children have died. Alfred died in the second quarter of 1931 aged 74.

**ES – STEPHENS, Edward** (*Newport/West Cowes*)

**Recorded as a pipemaker:** 1709–1710 (Newport/West Cowes)

**Likely to have been pipemaking:** +1709–1710+

1709 – Elizabeth Stephens of Newport, widow, and Edward Stephens (her son) of Newport, tobacco pipemaker, took Henry Kingswell apprentice on 3 Feb 1709 (NBAI Ref. NBC/3/53). Edward Stephens married at West Cowes in 1710 (Oswald 1975, 173).

Although Edward married in West Cowes, this may have been where his bride was from and he may well have still been working in Newport.

**ES – STEPHENS, Elizabeth** (*Newport and Gosport*)

**Recorded as a pipemaker:** 1709 (Newport); 1719 (Gosport)

**Likely to have been pipemaking:** +1709–1719+

**Married:** Yes (husband's name unknown)

**Children:** Edward (b. Newport)

1709 – Elizabeth Stephens of Newport, widow, and Edward Stephens (her son) of Newport, tobacco pipemaker, took Henry Kingswell apprentice on 3 Feb 1709 (NBAI Ref. NBC/3/53). 1719 – Elizabeth Stephens of Gosport took John Bray alias Stephens of Newport apprentice on 3 Aug 1719, to learn the trade of tobacco pipemaking (NBAI Ref. NBC/3/103).

**IS – STEPHENS, John (I)** (*Newport*)

**Recorded as a pipemaker:** 1708–1716 (Newport)

**Likely to have been pipemaking:** +1708–1716+

**Children:** Joseph

1708 Bondsman, Newport (Oswald 1975, 173).

1716 son Joseph apprenticed to Lovell Scott of Carisbrooke, cordwainer, 15 Aug 1716 (NBAI Ref. NBC/3/89).

There are later references of 1736 and 1743 to a John Stephens of Newport, which could relate to either this maker or to John Stephens II (see John Stephens II below for details).

**IS – STEPHENS, John (II)** (*Newport*)

**Recorded as a pipemaker:** 1719 (Gosport); 1736–51 (Newport)

**Likely to have been pipemaking:** 1719–1751+

1719 John Bray alias Stephens of Newport apprenticed to Elizabeth Stephens of Gosport, Widow, 3 Aug 1719, to learn the trade of a tobacco pipemaker (NBAI, Ref. NBC/3/103). There is some uncertainty about who this reference relates to because of the recorded alias Stephens, since there are later records of a John Stephens in Newport between 1736 and 1751 (see below), while at the same time Fox & Hall (1979, 20) list a John Bray at Fareham, 1745–66 (see John Bray above). This suggests there were two contemporary pipemakers, one known as John Stephens alias Bray and the other simply as John Stephens. The following references all relate to a John Stephens working in Newport, the latest of which must be a second John Stephens (cf John (I) above). John Stephens was a significant manufacturer, with examples of his pipes being found on neighbouring parts of the mainland as well as in 1740s deposits from Louisbourg, Nova Scotia (Walker 1967).

1736 John Stephens is named in the counterpart of the lease of “1 message or tenement, backside and garden on north side

of Crocker Street Newport, I.W. Having the land of Stephen Sanders on east, the river on the north, certain lands in poss. of Thomas Redstone, gent., on the west and said street on south, for 7 years at annual rent of £5. (1) Whitehead Rutter of Newport, chirugion. (2) John Stephens of Newport, pipemaker” dated 13 Dec 1736 (MBD Ref. ELD.74). This reference could either refer to John Stephens I (see above) or John Stephens II.

In 1743 John Stephens was a tenant of land to the south of Lukely Brook, where he had a brew-house and malt-house in Crocker Street (Trott 2001, 41–43 & 53). This suggests that John Stephens was engaged in brewing as well as pipe making.

1751 John Stephens pipemaker of Newport took an apprentice (Oswald 1975, 173).

**RS – STEPHENS, Richard** (*Newport*)

**Recorded as a pipemaker:** 1719–1720

**Likely to have been pipemaking:** +1719–1720+

**Married:** Jane

1719 took Henry Burt of Newport apprentice 31 Mar 1719 (NBAI Ref. NBC/3/101).

1720 Took Mary Fox alias ?Mahormick apprentice to learn the work of a housewife on 31 Oct 1720 (NBAI Ref. NBC/3/109).

**SS – SUMMERS, Stephen** (*West Cowes/Newport*)

**Recorded as a pipemaker:** 1683

**Likely to have been pipemaking:** +1683+

**Married:** Yes, name not known

**Children:** At least two, names not known

1683 removal of Stephen Summers, tobacco pipe maker, his wife and two children, from West Cowes, in the parish of Northwood to Newport. The churchwardens and overseers of Northwood agree to keep the town of Newport free from expense of maintaining them, dated 22 Oct 1683 (NBCD Ref. NBC/1/83).

**TS – STRANGE, Thomas** (*Newport*)

**Recorded as a pipemaker:** 1654

**Likely to have been pipemaking:** +1654+

**Married:** Jane Meadmore, 1654 July 29, Newport, witness Stephen Harman.

(<http://www.yourtotalevent.com/people/STRANGE%20in%20Hampshire.htm>)

Recorded as a pipe maker at his marriage to Jane Meadmore at Newport in 1654.

**WS – SEVILL, William** (*Newport*)**Recorded as a pipemaker:** 1753**Likely to have been pipemaking:** 1753+

1753 – William Stephens of Newport, pipemaker, took William Seville of Newport apprentice on 1 Sep 1753 (NBAI Ref. NBC/3/256).

**WS – STEPHENS, William** (*Newport*)**Recorded as a pipemaker:** 1753**Likely to have been pipemaking:** +1753+

1753 – William Stephens of Newport, pipemaker, took William Seville of Newport apprentice on 1 Sep 1753 (NBAI Ref. NBC/3/256).

**CT – TILEY, Charles** (*Newport*)**Recorded as a pipemaker:** 1841–1851, 1871**Likely to have been pipemaking:** +1841–1888**Born:** c1821, Godshill

**Married:** 1. Ann Smith (b. c1826 Newport) Q2 1849 (FreeBMD) presumed dead by 1861; 2. Catherine (b. c1833 Lancashire)

**Children:** Dorcas (b. c1850, Newport), Mercy (b. c1851, Newport), Mary (b. c1863, Hampshire), Margaret (b. c1865, Hampshire)

**Died:** Probably the Charles Tiley who died aged 68 in Q1 1888, Isle of Wight (FreeBMD)

*Census Information*

**1841** – Aged 20 listed as a pipe maker living in East Street, Newport with his parents John (45) and Elizabeth (40) and siblings Stephen (18), Martha (16), Emma (14), John (12), Henry (10), George (8), Luke (6), Sarah (4) and Fanny (2) and his grandmother Martha Tiley (75).

**1851** – Aged 29 listed as a tobacco pipe maker journeyman living at Russell Street, Newport with his wife Ann (shoe binder, 25) and children Dorcas (1) and Mercy (0).

**1861** – Aged 40, widower, listed as a rifle maker boarding in Lugley Street, Newport.

**1871** – Aged 45 listed as a pipe maker living in South Street, Tontine Yard, Newport, with his second wife Catherine (38) and children Mary (8) and Margaret (6).

**1881** – Age 60 listed as a pipe maker living in Tontine Yard, Newport.

Charles was born c1821, although in the 1881 census his year of birth is given as c1826. He was the son of John and Elizabeth Tiley. Charles is listed as a pipemaker in 1841 and in 1851 as a journeyman tobacco pipe maker. He appeared

in the county court in 1853 for failure to pay for clothes (*Isle of Wight Observer*, 8 Jan); “Loosemore v. Tiley, for clothes. The plaintiff said he believed the defendant would not pay unless he was forced to do so. He was a pipe maker and had plenty of work. Judgement for the plaintiff; defendant to pay 8s. per month, and if the instalments are not kept paid the whole of the balance to become due at once, that an execution may be levied.” He appears to have married twice. His first wife was Ann with whom he had two daughters. By 1861 he is listed as a widower working as a rifle maker in Newport. There is no trace of his wife or children and no death records for any of them can be found. In 1862 he is recorded as a pipemaker again when he appeared at the petty sessions having been drunk and disorderly (*Hampshire Advertiser*, 6 Sept); “Drunkenness – Charles Tiley, pipemaker, was charged with being drunk and disorderly. It appeared that the defendant went home to his lodgings at Mr. Burnett’s, in Lugley-sreet, very drunk at about 1 o’clock that morning, and finding that it was no use knocking at the door, endeavoured to make a forcible entry by kicking in the panel. The police were called, and he was locked up. He was ordered to pay the costs, and 3s 6d damage done to the door; in default of payment within a week he was to be sent to hard labour for fourteen days.” By the time of the 1871 census he had a second wife, Catherine, and two more daughters, and he is still listed as a pipemaker. He cannot be found in the 1881 census and he is likely to be the Charles Tiley, aged 68, whose death is recorded in the first quarter of 1888 on the Isle of Wight.

**ET – TAYLOR, Elizabeth** (*Newport*)**Recorded as a pipemaker:** 1851–1861**Likely to have been pipemaking:** +1851–1861+**Born:** c1798 Fareham, Hampshire**Married:** James (b. c1799 Areton, Hampshire)

**Children:** Anne (b. c1836, Newport), Charlotte (b. c1841, Newport)

*Census information*

**1851** – Aged 53 listed as a pipe trimmer living in Newport, Isle of Wight with her husband James (journeyman stone mason, 52) and children Anne (needleworker, 15), Charlotte (scholar, 10), grandson Thomas (scholar, 10), son-in-law Henry Kirby (marine private, 34) and nephew

Henry Kirby (masons labourer, 16). This Henry Kirby is probably the same person who was living with pipemaker William Kirby in 1841.

**1861** – Aged 64 listed as a tobacco pipe trimmer living in Orchard Street, Newport with her husband James (mason, 64) and children Jane (sempstress, 32), Charlotte (stempstress, 19) and granddaughters Sarah (scholar 9) and Lucy (scholar, 11).

**1871** – Not found.

**WT – TOOGOOD, William** (*Newport / Southampton*)

**Recorded as a pipemaker:** 1861–1881 (Newport), 1901–1911 (Southampton)

**Likely to have been pipemaking:** c1855–1912

**Born:** c1840, Merstone, West Arreton

**Married:** Never married

**Children:** No children

**Died:** Q4, 1913 (Ancestry.co.uk)

#### *Census Information*

**1841** – Aged 1 (b. c1840) living with his family in Merstone, Arreton; father James (30, Ag. Lab.), mother Mary Ann (30) and sister Emma (4).

**1851** – Aged 11 (b. c1840) living with his family in East Afton Cottage, Freshwater; father James (45, Ag. Labourer), mother Mary Ann (44) sisters Emma (14), Frances (8) and Ellen (3). He and all his siblings had been born in Arreton.

**1861** – Aged 21 (b. c1840) pipe maker, living with his family at 4 South Mall Terrace, Carisbrooke; James (55, coalyard labourer), Mary Ann (52), Emma (24, dress maker), and Ellen (13, scholar).

**1871** – Aged 31 (b. c1840) pipe maker, living with his family at Coppins Bridge, 1 Mount Terrace, Newport; father James (65, labourer), mother

Mary Ann (63), sister Emma (34, dress maker). Also, Agnes Annie Chambers (6, granddaughter to James and Mary Ann).

**1881** – Aged 42 (b. c1839) pipemaker, lodging 43 South Street, Newport with Robert Hayzell (77, cutler) and his wife Selina (68) and 9 other lodgers.

**1891** – Not found.

**1901** – Aged 61 (b. c1840) pipe maker, lodging at 75 Lower Canal Walk, Southampton with James Durant (62, clay pipe maker) and his wife Elizabeth Durant (72, clay pipe maker) and 5 other lodgers.

**1911** – Aged 71 (b. c1840) pipemaker, living alone at 33 Bell Street, Southampton (signed with an X).

**1913** – Aged 73, death in Q4 on the Isle of Wight.

William was born about 1840 and spent at least the first eight years of his life in Merstone, West Arreton, where his siblings were born and father worked as an agricultural labourer. By 1851 the family had moved to Freshwater, where his father was still an agricultural labourer. At some point in the next decade William learnt how to make pipes since, in 1861, the family was in Carisbrooke and he was listed as a 21-year-old pipemaker. He was still with his parents in Newport in 1871, but by 1881 they had probably died and he was lodging in Newport, on both occasions listed as a pipemaker. He has not been traced in the 1881 census but, in both 1901 and 1911 he was living in Southampton, where he also worked as a pipemaker. He never married and was still illiterate in 1911, signing the census return with an 'X'. He died in 1913, aged 73, on the Isle of Wight. William was probably always an employee (journeyman), working for the established pipe-making firms.